

# CRIPPLE CREEK SERIES

## w/ SCROLL & TWIST LOCK PHOTO CONTROL

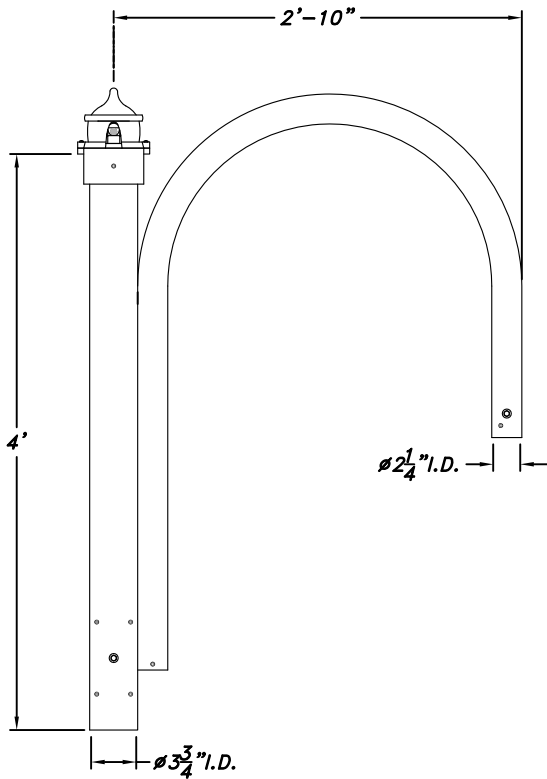

SCALE: 3/4"=1'-0"

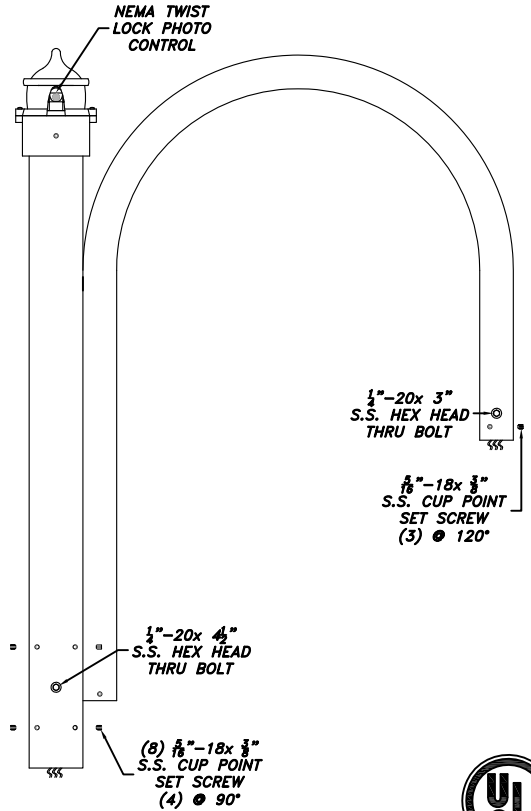

EXAMPLE

CCR-1-BC-17-V-FLAT-PSMH-150-208-III-BLK

CCR- SC - 1 - TLPC - \_\_\_\_\_  
Series Scroll Arms Accessories Color

FINIAL	SCROLL	ARMS	ACCESSORIES	COLOR OF POWDER COAT FINISH	
<input checked="" type="checkbox"/> ACORN <input type="checkbox"/> BALL <input type="checkbox"/> DOME	<input checked="" type="checkbox"/> (SC) SCROLL <input type="checkbox"/> NO SCROLL	<input type="checkbox"/> STAR <input checked="" type="checkbox"/> 1 <input type="checkbox"/> 2 <input type="checkbox"/> 3 <input type="checkbox"/> 4	<input checked="" type="checkbox"/> TWIST LOCK PHOTO CONTROL	<input type="checkbox"/> (BLK) BLACK <input type="checkbox"/> (BRZ) BRONZE <input type="checkbox"/> (GRN) GREEN	<input type="checkbox"/> (HG) HAND BRUSHED GREEN <input type="checkbox"/> (HR) HAND BRUSHED GRAY <input type="checkbox"/> CUSTOM _____

### ARM SPECIFICATION

ARM

The arm shall be made of extruded and cast aluminum components. Aluminum shall be certified as pure #356 alloy, free of any porosity, foreign materials or cosmetic fillers. Castings shall be uniform wall thickness with no warping or mold shifting. Minimum wall thickness shall be 3/16".

ELECTRICAL

All electrical wiring is ran through center shaft and arm and shall be UL-recognized and wired by a certified UL technician. The electrical assembly is prewired with quick disconnects for servicing. Fixture shall be UL certified for wet locations.

MOUNTING

Arm shall be mounted to  $\approx 3"$ O.D.x10"H. tenon with (8)  $\frac{5}{16}$ "-18x  $\frac{3}{8}$ " S.S. Cup Point Set Screws @ 90° and (1)  $\frac{1}{4}$ "-20x  $4\frac{1}{2}$ " S.S. Hex Head Cap Screw.

FINISH

Fixture finish shall consist of degreasing, phosphate acid etching with 140+ deionized water, rinsed, oven dry off and top coated with a thermoset TGIC super polyester powder coat finish designed not to chalk or fade for many years. All Niland Company powders must pass a minimum 3000-hour salt spray test for corrosion resistance.

CERTIFICATION

The Fixture shall be UL-Listed for wet location use, and all HID listings.

WARRANTY

Niland Company warrants to repair or replace, at our option, any equipment that fails due to defects in material or workmanship within one year from date of shipment. This warranty does not include failures as a result of improper installation, mishandling or misapplication. This guarantee is limited to repair or replacement only and does not include reimbursement for expense of installation, removal of equipment, transportation or any other expenses that may be incurred. Authorization must be obtained from Niland Company in El Paso, Texas before any material is returned.

Catalog Name: CCR-1 Date: 02.15.18  
 Revision History: N/A Revision #: 0  
 Niland Approval: Luis M. Gomez Customer Approval: \_\_\_\_\_ Page: 3 of 4



# Niland Company

NILAND COMPANY • PH: (915) 779-1405 • FAX: (915) 779-3618 • E-MAIL: INFO@NILANDCO.COM  
 320 N. Clark El Paso, Tx 79905 • PH: 800-848-9013 • FAX: 888-779-3065 • WEB PAGE: HTTP://www.nilandco.com