

# AUDI SERIES

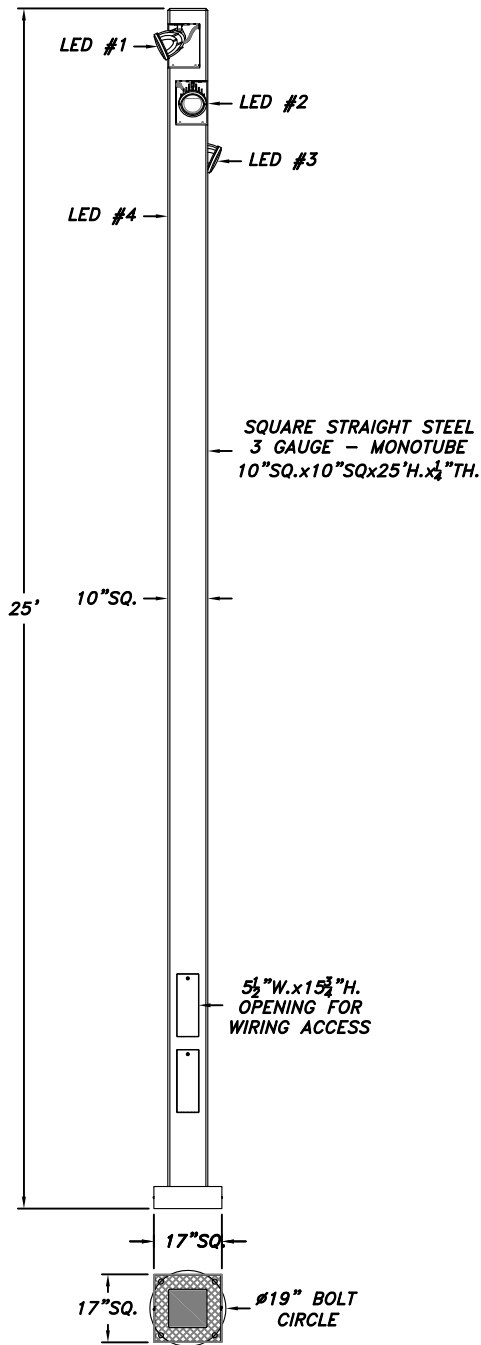

SCALE: 1/4"=1'-0"

Catalog Name:

**AU-17-SSQ10-25-AU-LED-4**

Revision # 0

Date: 02.15.18

Page: 1 of 3

Revision History: N/A

Niland Approval: Luis M. Gomez

Customer Approval:

## CSI POLE SPECIFICATION

### I. POLE

Post shall be 10"x10" square straight smooth steel pole. Shaft extrusion shall be of uniform wall thickness with no warping or mold shifting. Minimum wall thickness shall be 3 gauge (1/4"). There are no exterior welds to finish. A bolt plate shall be welded on bottom of the extrusion. Wiring shall be accessed through the access door. Door shall be secured with two stainless steel screws.

### II. ANCHORAGE DETAIL

Post base requires (4)  $\varnothing$ 1"x36"L. hot galvanized L-type anchor bolts with 4" minimum projection each.

### III. LED MODULES

To Ensure good thermal contact, no gaps will be left between module and cooler. PrevalLED Core Z3 modules are mounted to heatsink with two M3 screws. The LED module and all its components will not be mechanically stressed. Mounting and mechanical support of the reflector in this configuration will be provided by the luminaire body reflector mounting structures. The output voltage of the ECG is below 220v-240vAC. LED module is 4000 kelvin 85 CRI.

## FINISHES

### Five Year Powder Coating Warranty

Niland Company factory-applied powder coatings are warranted against peeling, excessive fading and cracking under normal climatic exposure for a period of five years from date of shipment. Damage to finish coating caused by abuse or mishandling during installation is not covered by warranty. This warranty is limited to the repair or replacement of the material involved and does not include reimbursement of consequential expenses such as installation or removal of equipment or transportation costs.

### I. STANDARD FINISH

Satin iron achieved by rotary sanding, blasting and phosphate conversion coating.

### II. THERMOSET POWDER PAINT FINISH

Pretreatment shall consist of degreasing phosphate acid-etching with 140° and de-ionizing water, rinsed and oven dried.

### FINISH COAT

Thermoset TGIC super polyester powder coat finish electrostatically applied, oven cured and bonded at approximately 420° F to a minimum dry film thickness of 1.6 mils. All Niland powders must pass a minimum 3000-hour salt-spray test for corrosion resistance. The National Association of Architectural Metal Manufacturers, Metal Finishes Manual rates the outdoor life of these powders at 15-plus years.

### III. LIQUID FINISH

Optional liquid finish is first prime coated then finished with a two part liquid epoxy coat.

## WARRANTY

Niland Company warrants to repair or replace, at our option, any equipment that fails due to defects in material or workmanship within one year from date of shipment. This warranty does not include failures as a result of improper installation, mishandling or misapplication. This guarantee is limited to repair or replacement only and does not include reimbursement for expense of installation, removal of equipment, transportation or any other expenses that may be incurred. Authorization must be obtained from Niland Company in El Paso, Texas before any material is returned.

**NILAND/LED** 

Leading The Way For Solid State Street Lighting

**OSRAM SYLVANIA** 

**QUICK 60+ Warranty**  
On Parts and Labor

NILAND COMPANY • PH: (915) 779-1405 • FAX: (915) 779-3618 • E-MAIL: INFO@NILANDCO.COM  
320 N. Clark El Paso, Tx 79905 • PH: 800-648-9013 • FAX: 888-779-3065 • WEB PAGE: HTTP://www.nilandco.com

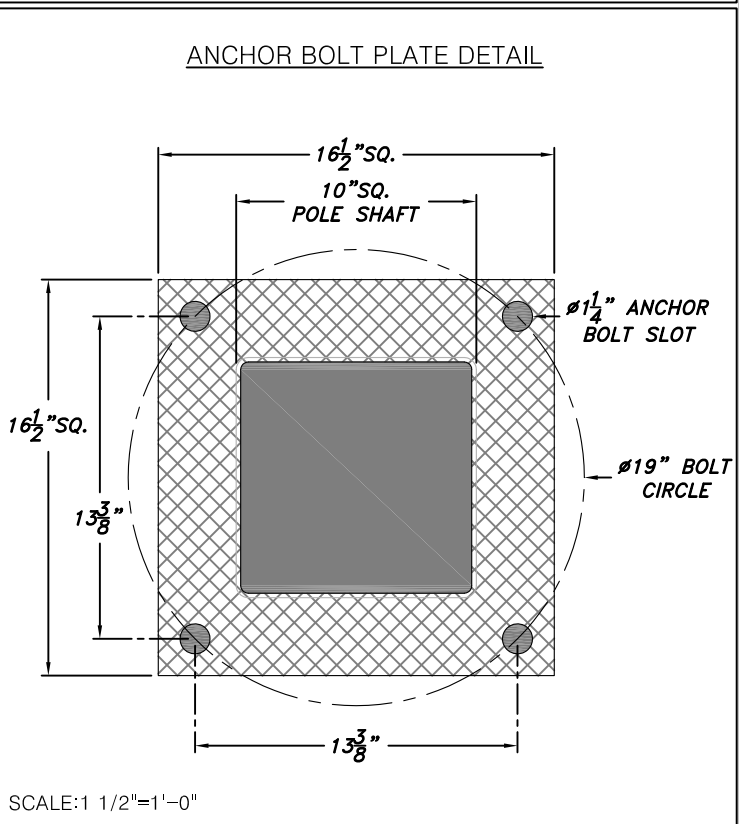
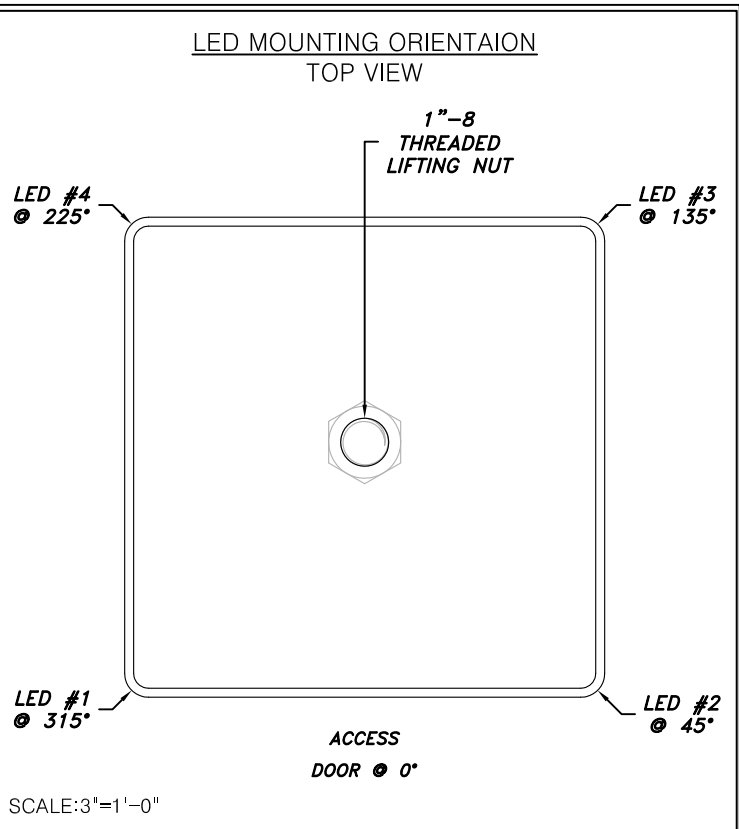
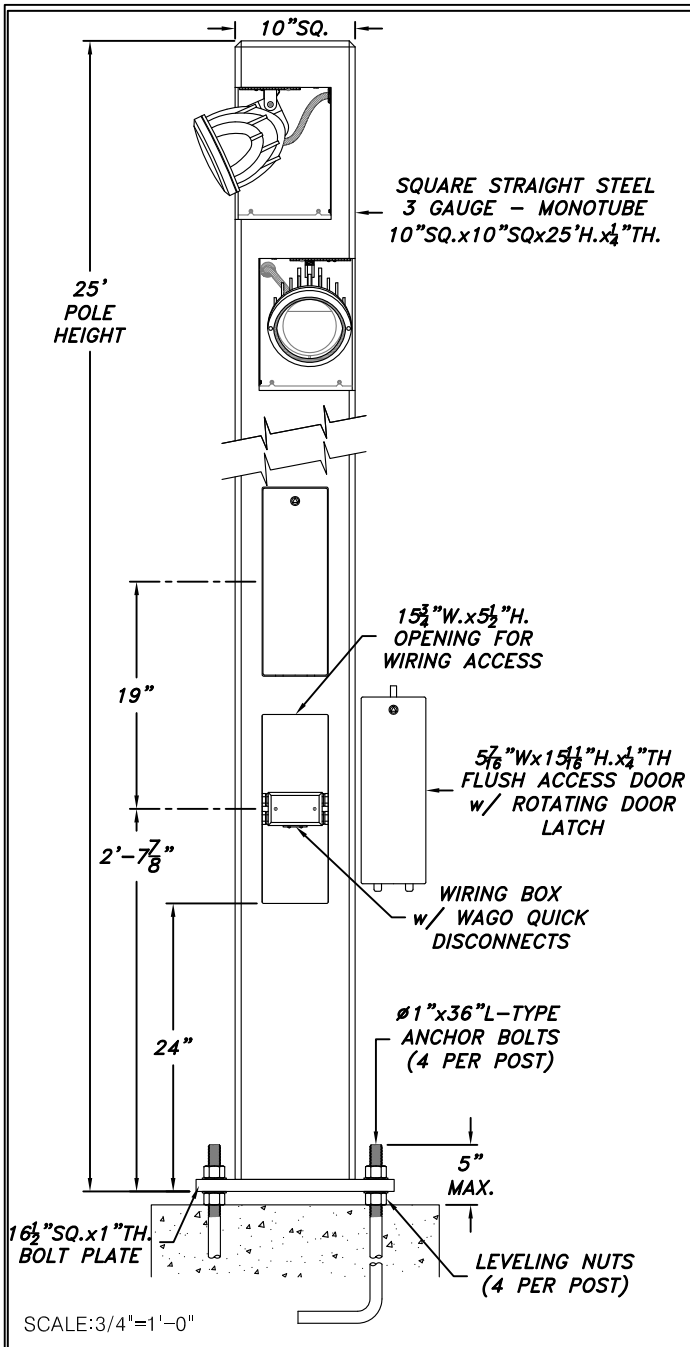

AUDI Series-16 1/2" Bolt Plate-Steel Square 10"-25'  
Height  
AU-16.5-SSQ10-25

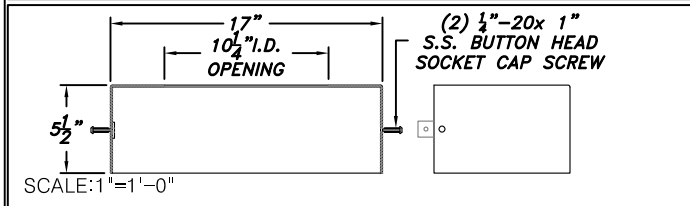

AUDI Series-17" Anchor Bolt Cover  
AU-17

Catalog Name: AU-17-SSQ10-25-AU-LED-4 Date: 02.15.18  
Revision History: N/A Revision #: 0

**NILAND/LED** USA

Leading The Way For Solid State Street Lighting

**OSRAM SYLVANIA** QUICK 60+ Warranty On Parts and Labor

NILAND COMPANY • PH: (915) 779-1405 • FAX: (915) 779-3618 • E-MAIL: INFO@NILANDCO.COM  
320 N. Clark El Paso, Tx 79905 • PH: 800-646-9013 • FAX: 888-779-3065 • WEB PAGE: HTTP://www.nilandco.com

FULL CUT OFF:  
DARK SKY COMPLIANT

# AUDI LED SERIES

## AU-LED

IP 66 RATED  
LED CHAMBER

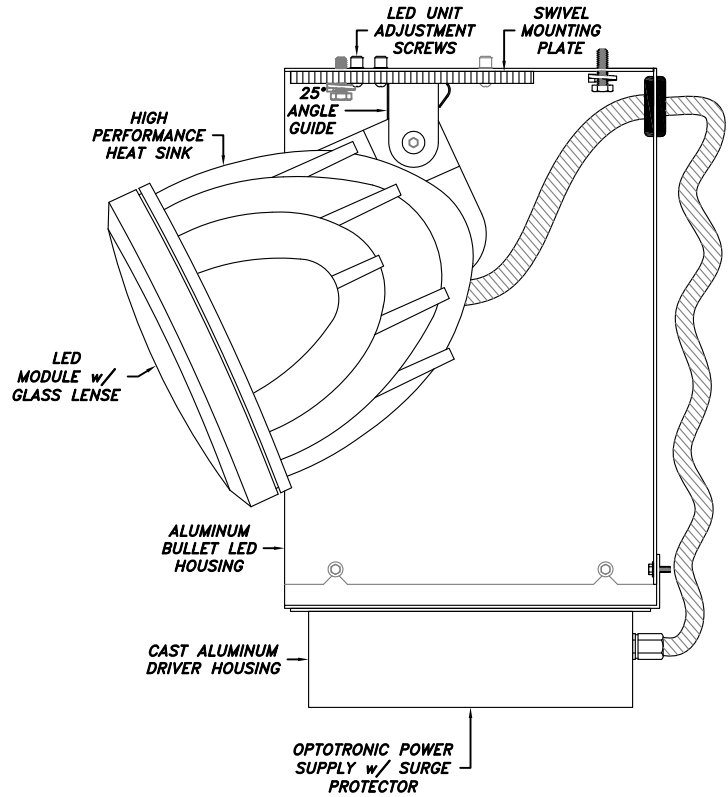
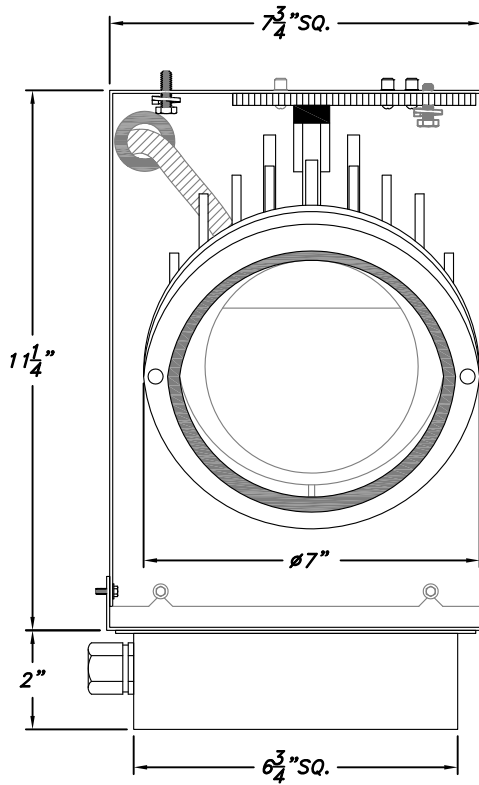

SCALE: 3"=1'-0"

STANDARD KELVIN	WATTAGE ACTUAL = LUMENS	VOLTAGE RANGE-AC	LIGHT DISTRIBUTION	COLOR OF POWDER COAT FINISH
4000	47w = 4089Lmns	120/277v	TYPE V	DB107 MICACEOUS IRON ORE SILVER

### LUMINAIRE SPECIFICATION

**HOUSING**

The bullet luminaire shall be core cast aluminum. Aluminum shall be certified as pure #356 alloy, free of any porosity, foreign materials or cosmetic fillers. Castings shall be uniform wall thickness with no warping or mold shifting. Minimum wall thickness shall be 3/16". Electrical components are one piece plug-in. LED circuit board shall be mounted with three stainless steel screws and a mounting frame. The luminaire is designed for either a type V light distribution pattern.

**LED POWER SUPPLY**

Up to 100,000 hours Mean Time Before Failure (MTBF). Each factor adjustable setting draws between 300 to 600 milliamps of power. Only 1 power supply is used for up to 125 LED watts each enclosed fixture. Multiple circuit detection and protections. Each unit is rated up to 16 amps of power. Input voltage range of 120-277vAC. Minimum operating temperature -22°F (-30°C) Maximum operating temperature 140°F (60°C).

**LED CIRCUIT BOARD**

1 individual, CREE XPE LED's rated for up to 100,000 hours service life. 4000 Kelvin. Lead free and RoHS compliant.

**MOUNTING**

Luminaire is mounted to square housing using the swivel mounting plate.

**CERTIFICATION**

The fixture shall be UL Certified for wet location use.

**FINISH-AAMA-2604-5**

Fixture finish shall consist of degreasing, phosphate acid etching with 140+ deionized water, rinsed, oven dry off and top coated with a thermoset TGIC super polyester powder coat finish designed not to chalk or fade for many years. All Niland Company powders must pass a minimum 3000-hour salt spray test for corrosion resistance.

**WARRANTY**

Quick 60+ month warranty on LED module and electronic driver. Please contact manufacturer for more details.

**PHOTOMETRICS**

Complete photometric data for all fixtures is available in IES-formatted. A certified independent laboratory performs all testing. Call the Niland Company directly for more information.

Catalog Name: AU-17-SSQ10-25-AU-LED-4 Date: 02.15.18

Revision History: N/A Revision #: 0

Niland Approval: Luis M. Gomez Customer Approval: \_\_\_\_\_ Page: 3 of 3



QUICK 60+ Warranty  
On Parts and Labor

NILAND COMPANY • PH: (915) 779-1405 • FAX: (915) 779-3618 • E-MAIL: INFO@NILANDCO.COM  
320 N. Clark El Paso, Tx 79905 • PH: 800-648-9013 • FAX: 888-779-3065 • WEB PAGE: HTTP://www.nilandco.com