

# EAGLE SERIES

## EGL

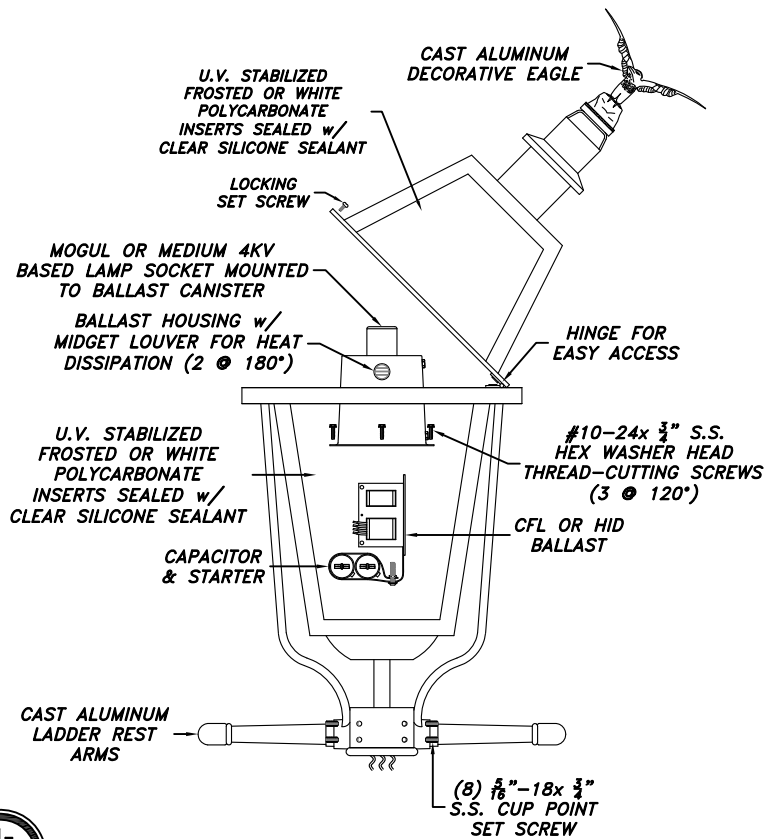
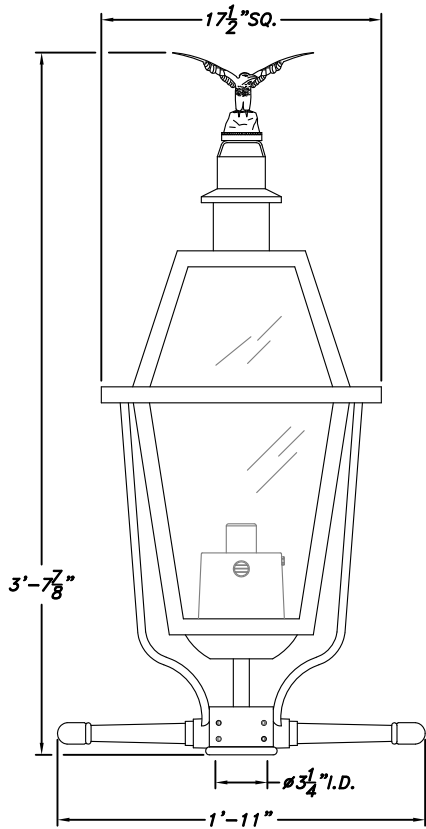

SCALE: 1"=1'-0"

E.P.A.=2.59 SQ.FT.

**EXAMPLE**  
EGL-PSMH-150-208-BLK

EGL- \_\_\_\_\_ - \_\_\_\_\_ - \_\_\_\_\_ - \_\_\_\_\_  
Series Ballast Wattage Voltage Color

INSERTS	LIGHT SOURCE	WATTAGE-SOCKET MEDIUM MOGUL	VOLTAGE	COLOR OF POWDER COAT FINISH
<input type="checkbox"/> FROSTED (CLEAR) <input type="checkbox"/> WHITE (MILKY)	<input type="checkbox"/> INC <input type="checkbox"/> CFL <input type="checkbox"/> HPS <input type="checkbox"/> PSMH <input type="checkbox"/> LED	<input type="checkbox"/> 50w <input type="checkbox"/> 70w <input type="checkbox"/> 100w <input type="checkbox"/> 150w <input type="checkbox"/> 175w <input type="checkbox"/> 250w	<input type="checkbox"/> 120v <input type="checkbox"/> 208v <input type="checkbox"/> 240v <input type="checkbox"/> 277v <input type="checkbox"/> 480v <input type="checkbox"/> MULTITAP 120v 240v 208v 277v PLEASE SPECIFY VOLTAGE	<input type="checkbox"/> (BLK) BLACK <input type="checkbox"/> (BRZ) BRONZE <input type="checkbox"/> (GRN) GREEN <input type="checkbox"/> (HG) HAND BRUSHED GREEN <input type="checkbox"/> (HR) HAND BRUSHED GRAY <input type="checkbox"/> CUSTOM _____

### LUMINAIRE SPECIFICATION

**HOUSING**

The post top shall be core cast aluminum. Aluminum shall be certified as pure #356 alloy, free of any porosity, foreign materials or cosmetic fillers. Castings shall be uniform wall thickness with no warping or mold shifting. Minimum wall thickness shall be 3/16". Electrical components are mounted in the ballast canister. The ballast canister shall be mounted in the post top with three stainless steel screws. The optional refractor will be a borosilicate glass refractor designed for either a type III or type V light distribution pattern.

**ELECTRICAL**

All electrical components and materials shall be UL-recognized and wired by a certified UL technician. All Niland ballasts are high power factor rated for -30°C/-20°F starting. Medium and Mogul base sockets are 4 KV rated. The electrical assembly is prewired with quick disconnects for servicing. Fixture shall be UL certified for wet locations.

**MOUNTING**

Fixture shall be mounted to 3" O.D. x 3"H. tenon with stainless steel allen head set screws (8 @ 90°)

**RELAMPING**

The lamp is accessed by loosening the (2) Flat Head Screw that are mounted on the luminaire lid.

**FINISH**

Fixture finish shall consist of degreasing, phosphate acid etching with 140+ deionized water, rinsed, oven dry off and top coated with a thermoset TGIC super polyester powder coat finish designed not to chalk or fade for many years. All Niland Company powders must pass a minimum 3000-hour salt spray test for corrosion resistance.

**CERTIFICATION**

The Fixture shall be UL-Listed for wet location use, and all HID listings.

**WARRANTY**

Fixture shall be warranted to be free of defects for five years. Ballast components shall carry the ballast manufacturers limited warranty of two years.

**PHOTOMETRICS**

Complete photometric data for all fixtures is available in IES-formatted 3.5 disks. A certified independent laboratory performs all testing. Call the Niland Company directly for more information.

Catalog Name: EGL Date: 02.15.18  
 Revision History: N/A Revision #: 0



# Niland Company