

# DAVENPORT SERIES

## DAV-1

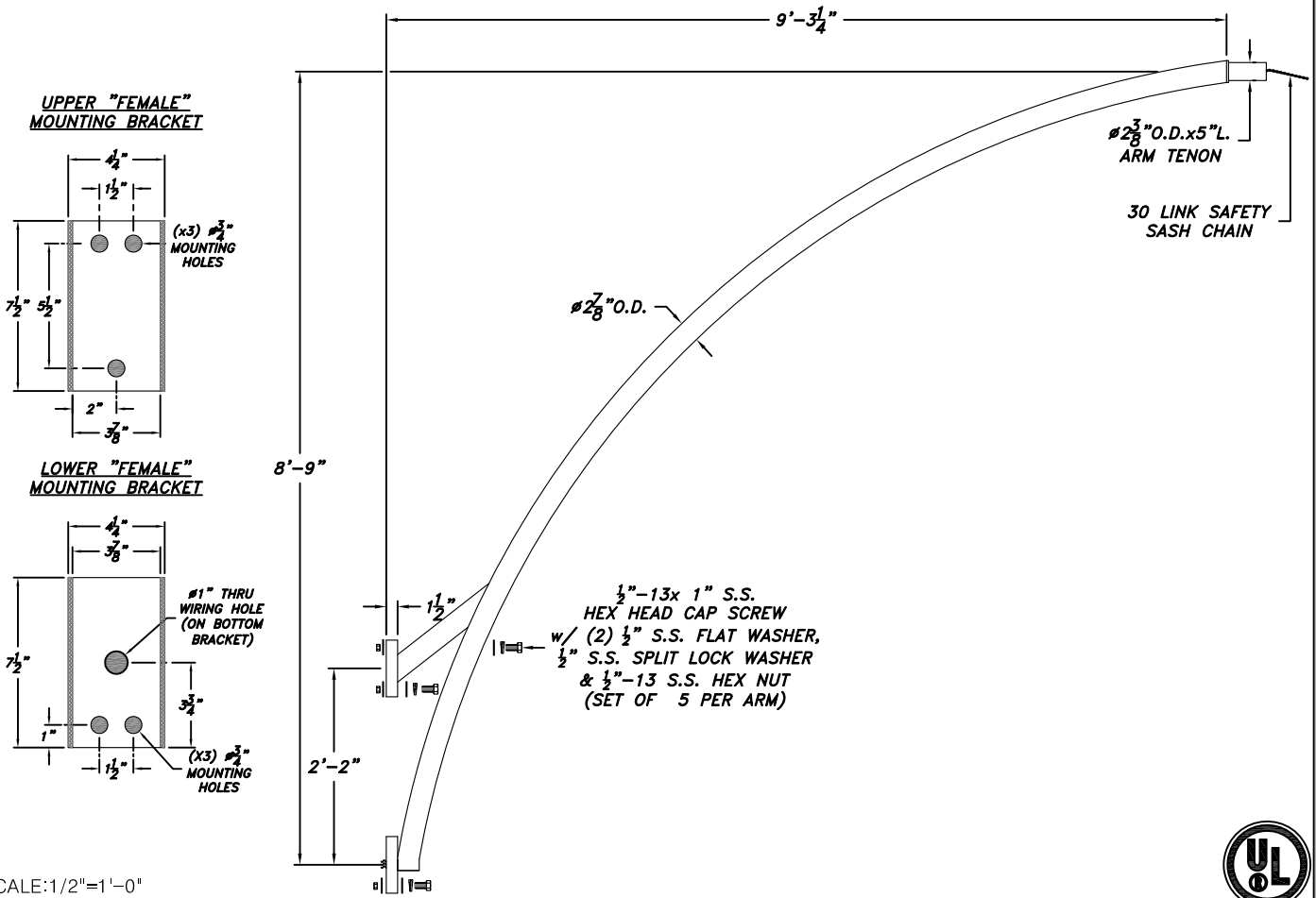

EXAMPLE  
DAV-1-BLK

DAV- 1 -  
Series Arms Color

**ARM PER POLE**

- SINGLE
- DOUBLE

**COLOR OF POWDER COAT FINISH**

- (BLK) BLACK       (HG) HAND BRUSHED GREEN
- (BRZ) BRONZE       (HR) HAND BRUSHED GRAY
- (GRN) GREEN       CUSTOM \_\_\_\_\_

### ARM SPECIFICATION

**ARM**

The arms shall be steel construction. Extrusion shall be 11 gauge (1/8") wall thickness with no warping or mold shifting. Electrical wiring shall run through arm up and out through the #2 5/8" opening.

**ELECTRICAL**

All electrical wiring is ran through center shaft and arm and shall be UL-recognized and wired by a certified UL technician. The electrical assembly is prewired with quick disconnects for servicing. Fixture shall be UL certified for wet locations.

**MOUNTING**

Arm shall be mounted to a (2) 3 3/4"W. x 7 1/2"H. x 1 1/2"D. arm bracket using (3) steel hex head set screws for fastening.

**FINISH**

Fixture finish shall consist of degreasing, phosphate acid etching with 140+ deionized water, rinsed, oven dry off and top coated with a thermoset TGIC super polyester powder coat finish designed not to chalk or fade for many years. All Niland Company powders must pass a minimum 3000-hour salt spray test for corrosion resistance.

**CERTIFICATION**

The Fixture shall be UL-Listed for wet location use, and all HID listings.

**WARRANTY**

Fixture shall be warranted to be free of defects for five years. Ballast components shall carry the ballast manufacturers limited warranty of two years.

Catalog Name: DAV-1      Date: 02.15.18

Revision History: N/A      Revision #: 0

Niland Approval: Luis M. Gomez Customer Approval: \_\_\_\_\_ Page: 3 of 4



# Niland Company

NILAND COMPANY      • PH: (915) 779-1405 • FAX: (915) 779-3618 • E-MAIL: INFO@NILANDCO.COM  
320 N. Clark El Paso, Tx 79905      • PH: 800-848-9013 • FAX: 888-779-3065 • WEB PAGE: HTTP://www.nilandco.com