

# GRAND TAWAS-20 SERIES

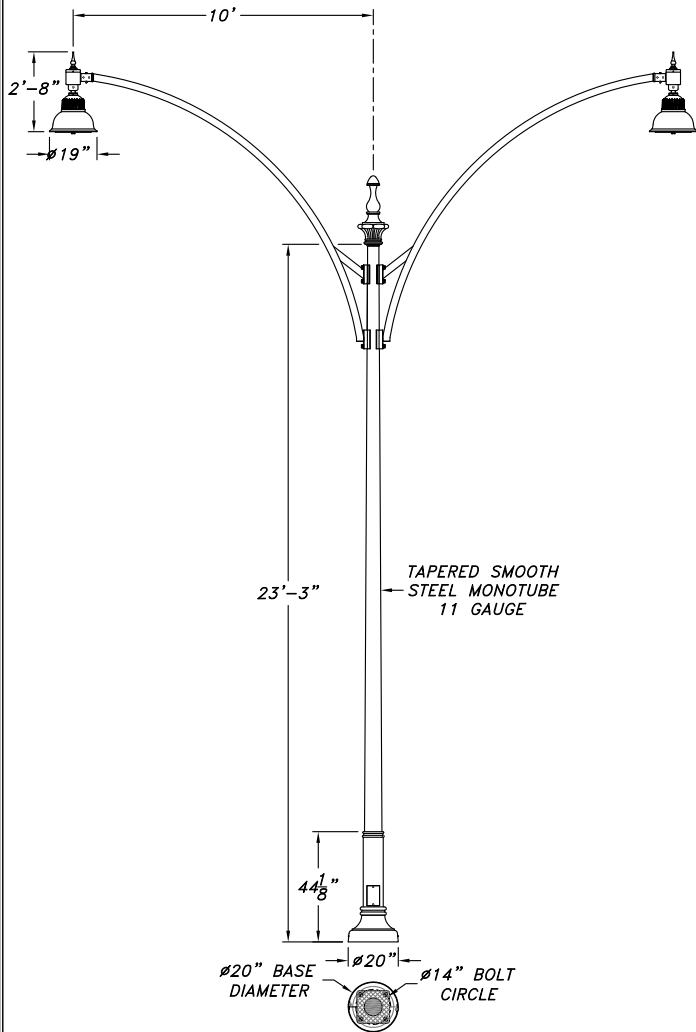

SCALE:NTS

Catalog Name:

**GTW-20-TSS-23.25-DAV-2-BY-19-H-FLAT**

Revision #: 0

Date: 02.15.18

Page: 1 of 5

Revision History: N/A

Niland Approval: Luis M. Gomez

Customer Approval:

## CSI POLE SPECIFICATION

### I. BASE

Base shall be cast aluminum. Aluminum shall be certified as pure 356 copper free of any porosity, foreign materials or cosmetic fillers. Base casting shall be of uniform wall thickness with no warping or mold shifting. Minimum wall thickness shall be .250". Cast aluminum access cover shall be secured with two to four stainless steel screws.

### II. POLE

Post shall be tapered smooth steel pole with a reinforced  $\varnothing 2.7/8" \times 6'h$ . tenon. Shaft shall be of uniform wall thickness with no warping or mold shifting. Minimum wall thickness shall be 11 gauge (1/8"). A bolt plate shall be welded on bottom of the extrusion.. A 13"SQ.x 1"TH. bolt plate w/ 4 slots for anchor bolt placement shall be welded to the bottom of the extrusion.

### III. ANCHORAGE DETAIL

Pole base requires (4)  $\varnothing 1" \times 36"$  hot galvanized L.-type Anchor Bolts with 5" maximum projection each. Anchor Bolts are ASTM A-36 and ASTM A-153 at galvanized.

### IV. ARM

The arms shall be steel construction. Extrusion shall be 11 gauge (1/8") wall thickness with no warping or mold shifting. Electrical wiring shall run through arm up and out through the  $\varnothing 2.5/8"$  opening.

### V. HOUSING

The pendant mount luminaire shall be core cast aluminum. Aluminum shall be certified as pure #356 alloy, free of any porosity, foreign materials or cosmetic fillers. Castings shall be uniform wall thickness with no warping or mold shifting. Minimum wall thickness shall be 3/16". Electrical components are mounted in the pendant luminaire with two stainless steel screws. 111-D reflector mounts lamp in a horizontal position. A optional refractor globe shall be molded of acrylic with external refractors designed for a Type III or V light distribution pattern. The reflector shall be mounted in the luminaire with four S.S. Screws.

### VI. ELECTRICAL

All electrical components and materials shall be UL-recognized and wired by a certified UL technician. All Niland ballasts are high power factor rated for  $-30^{\circ}C/-20^{\circ}F$  starting. Medium and Mogul base sockets are 4 KV rated. The electrical assembly is prewired with quick disconnects for servicing. Fixture shall be UL certified for wet locations.

## FINISHES

### Five Year Powder Coating Warranty

Niland Company factory-applied powder coatings are warranted against peeling, excessive fading and cracking under normal climatic exposure for a period of five years from date of shipment. Damage to finish coating caused by abuse or mishandling during installation is not covered by warranty. This warranty is limited to the repair or replacement of the material involved and does not include reimbursement of consequential expenses such as installation or removal of equipment or transportation costs.

### I. STANDARD FINISH

Satin iron achieved by rotary sanding, blasting and phosphate conversion coating.

### II. THERMOSET POWDER PAINT FINISH

Pretreatment shall consist of degreasing phosphate acid-etching with 140° and de-ionizing water, rinsed and oven dried.

### FINISH COAT

Thermoset TGIC super polyester powder coat finish electrostatically applied, oven cured and bonded at approximately 420° F to a minimum dry film thickness of 1.6 mils. All Niland powders must pass a minimum 3000-hour salt-spray test for corrosion resistance. The National Association of Architectural Metal Manufacturers, Metal Finishes Manual rates the outdoor life of these powders at 15-plus years.

### III. LIQUID FINISH

Optional liquid finish is first prime coated then finished with a two part liquid epoxy coat.

### WARRANTY

Niland Company warrants to repair or replace, at our option, any equipment that fails due to defects in material or workmanship within one year from date of shipment. This warranty does not include failures as a result of improper installation, mishandling or misapplication. This guarantee is limited to repair or replacement only and does not include reimbursement for expense of installation, removal of equipment, transportation or any other expenses that may be incurred. Authorization must be obtained from Niland Company in El Paso, Texas before any material is returned.



# Niland Company

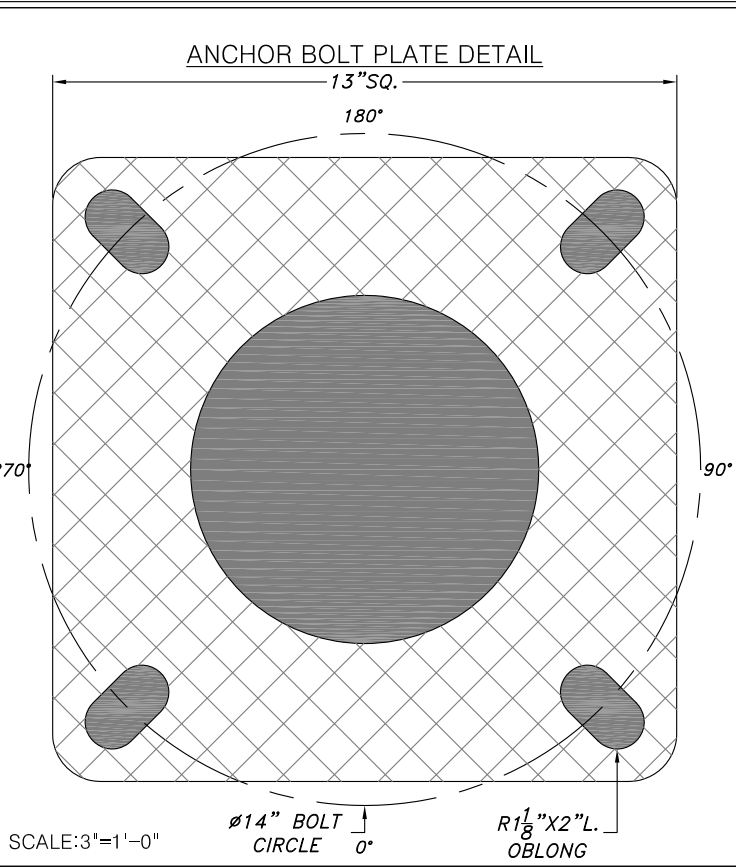
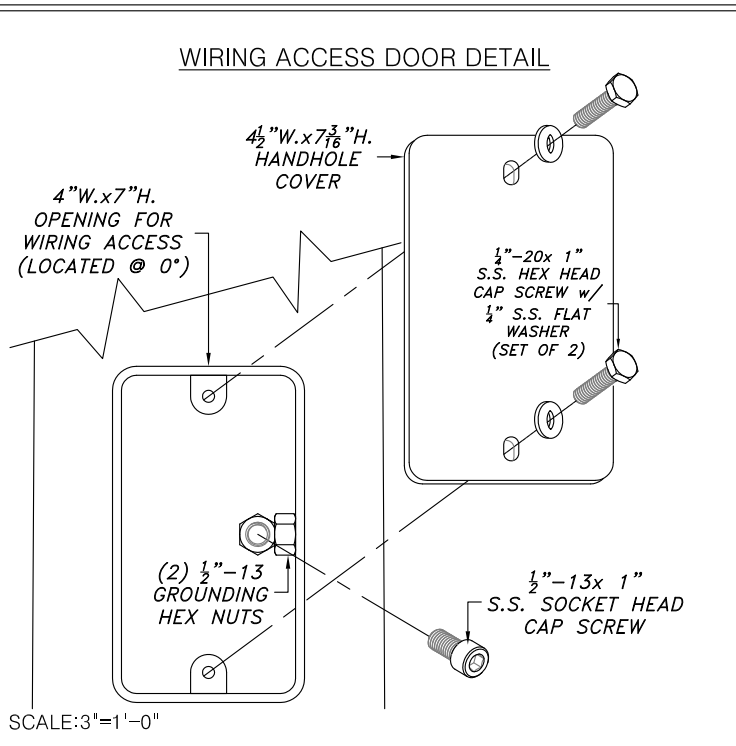
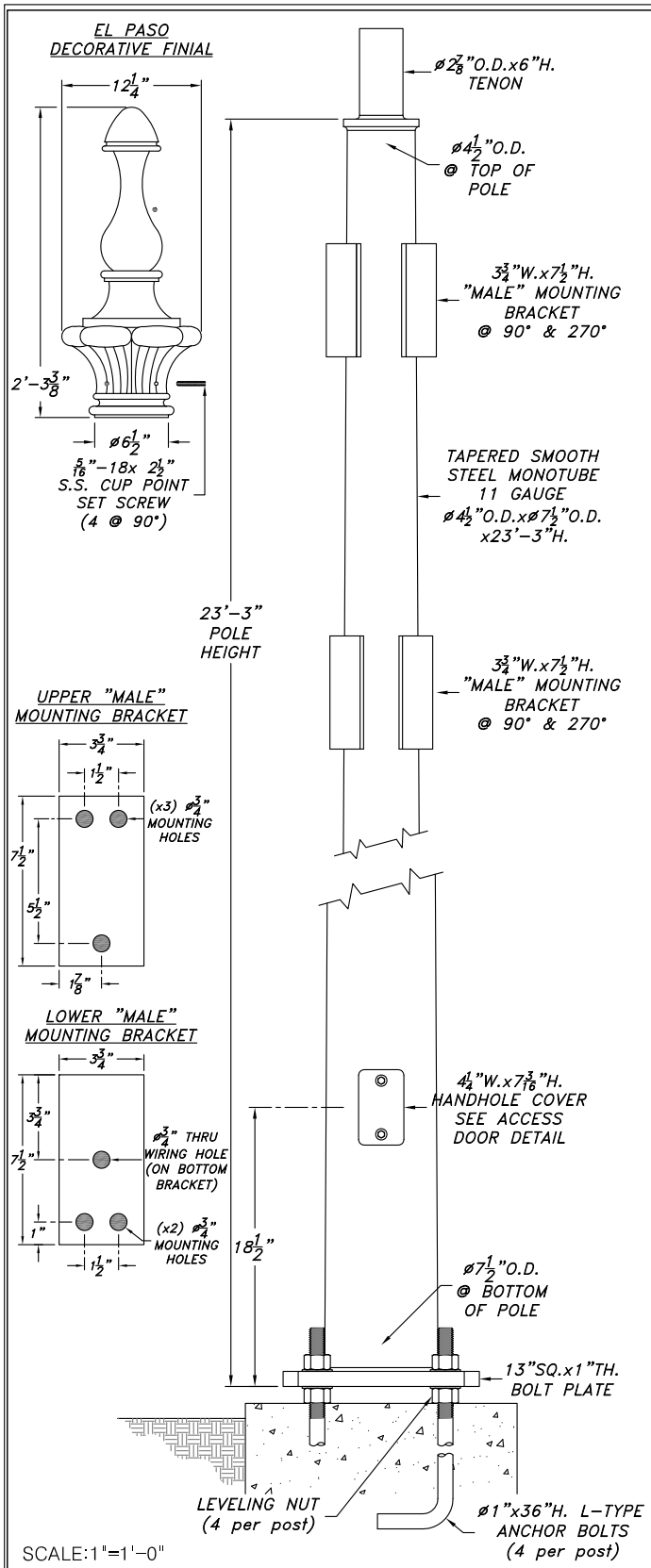

COLOR OF POWDER COAT FINISH

<input type="checkbox"/> (BLK) BLACK	<input type="checkbox"/> (HG) HAND BRUSHED GREEN
<input type="checkbox"/> (BRZ) BRONZE	<input type="checkbox"/> (HR) HAND BRUSHED GRAY
<input type="checkbox"/> (GRN) GREEN	<input type="checkbox"/> CUSTOM _____

**Steel Series-13" Bolt Plate-Tapered Smooth Steel Pole-23'-3" Height**  
 SS-13-TSS-23.25

Catalog Name: GTW-20-TSS-23.25-DAV-2-BY-19-FLAT Date: 02.15.18  
 Revision History: N/A Revision #: 0  
 Niland Approval: Luis M. Gomez Customer Approval: \_\_\_\_\_ Page: 2 of 5

**Niland Company**

NILAND COMPANY • PH: (915) 779-1405 • FAX: (915) 779-3618 • E-MAIL: INFO@NILANDCO.COM  
 320 N. Clark El Paso, Tx 79905 • PH: 800-648-9013 • FAX: 888-779-3065 • WEB PAGE: HTTP://www.nilandco.com

# GRAND TAWAS-20 SERIES

## GTW-20-CS

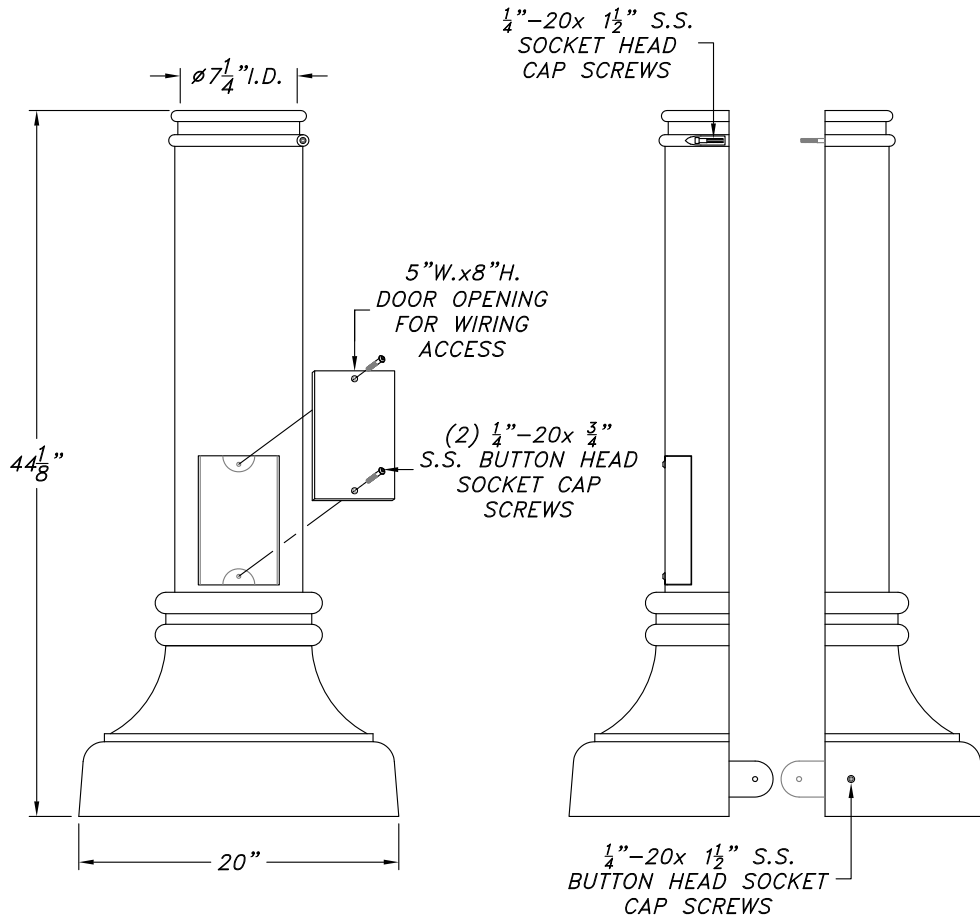

SCALE: 1"=1'-0"

**EXAMPLE**  
GTW-20-CS-BLK

GTW-20-CS-\_\_\_\_\_  
Series Size Color

### COLOR OF POWDER COAT FINISH

- |                                       |  |
|---------------------------------------|--|
| <input type="checkbox"/> (BLK) BLACK  | <input type="checkbox"/> (HG) HAND BRUSHED GREEN |
| <input type="checkbox"/> (BRZ) BRONZE | <input type="checkbox"/> (HR) HAND BRUSHED GRAY  |
| <input type="checkbox"/> (GRN) GREEN  | <input type="checkbox"/> CUSTOM _____            |

## BASE SPECIFICATION

### BASE

Base shall be cast aluminum. Aluminum shall be certified as pure 356 copper free of any porosity, foreign materials or cosmetic fillers. Base casting shall be of uniform wall thickness with no warping or mold shifting. Minimum wall thickness shall be .250". Cast aluminum access cover shall be secured with four stainless steel screws.

### MOUNTING

Base shall be wrapped around steel pole and fastened with (4) Button Head Screws.

### FINISH

Fixture finish shall consist of degreasing, phosphate acid etching with 140+ deionized water, rinsed, oven dry off and top coated with a thermoset TGIC super polyester powder coat finish designed not to chalk or fade for many years. All Niland Company powders must pass a minimum 3000-hour salt spray test for corrosion resistance.

### CERTIFICATION

The Fixture shall be UL-Listed for wet location use, and all HID listings.

### WARRANTY

Fixture shall be warranted to be free of defects for five years. Ballast components shall carry the ballast manufacturers limited warranty of two years.

Catalog Name: GTW-20-TSS-23.25-DAV-2-BY-19-FLAT Date: 02.15.18

Revision History: N/A Revision #: 0

Niland Approval: Luis M. Gomez Customer Approval: \_\_\_\_\_ Page: 3 of 5



# Niland Company

NILAND COMPANY • PH: (915) 779-1405 • FAX: (915) 779-3618 • E-MAIL: INFO@NILANDCO.COM  
320 N. Clark El Paso, Tx 79905 • PH: 800-648-9013 • FAX: 888-779-3065 • WEB PAGE: HTTP://www.nilandco.com

# DAVENPORT SERIES

## DAV-1

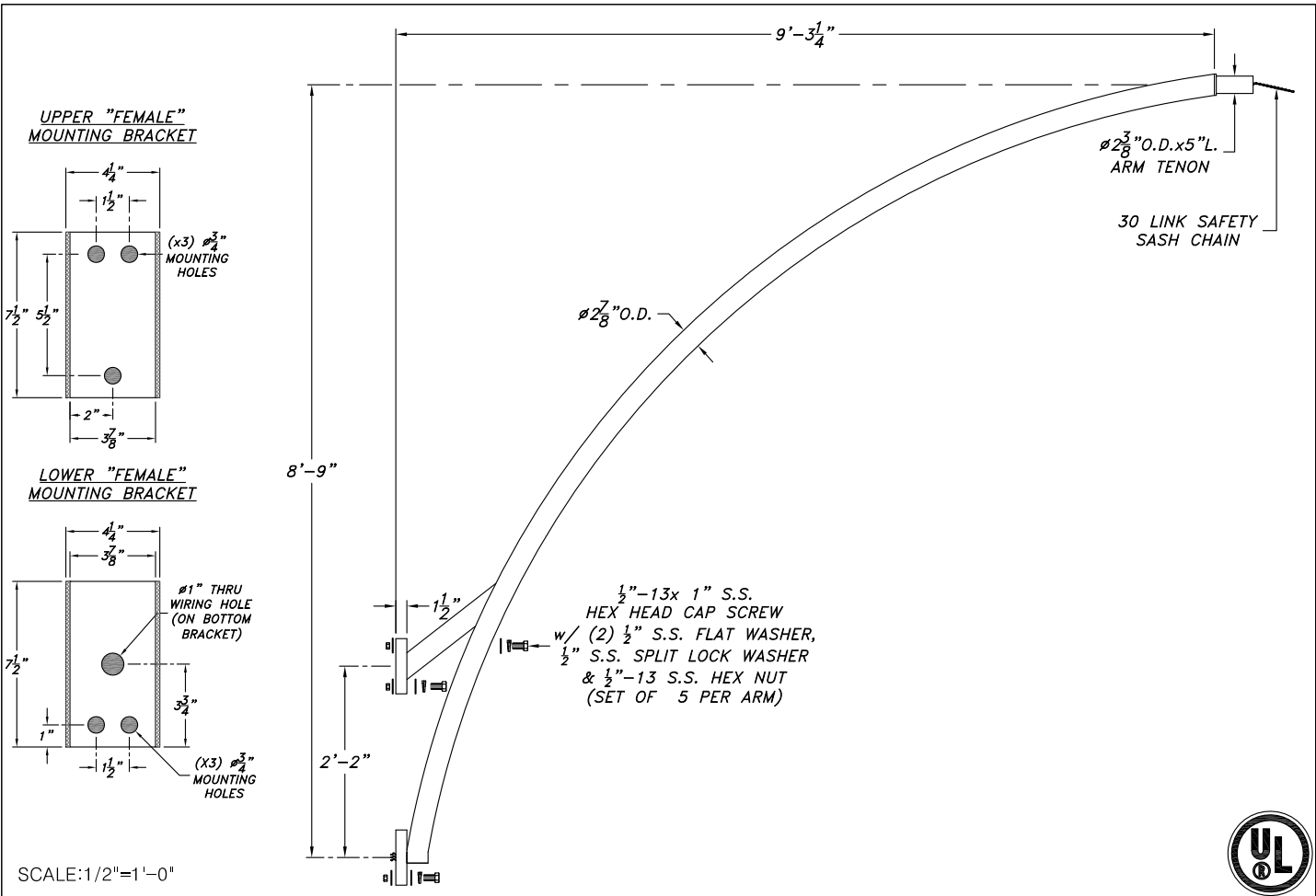

EXAMPLE  
DAV-1-BLK

DAV- 2 -       
Series Arms Color

**ARM PER POLE**

- SINGLE
- DOUBLE

**COLOR OF POWDER COAT FINISH**

- (BLK) BLACK       (HG) HAND BRUSHED GREEN
- (BRZ) BRONZE       (HR) HAND BRUSHED GRAY
- (GRN) GREEN       CUSTOM \_\_\_\_\_

### ARM SPECIFICATION

**ARM**

The arms shall be steel construction. Extrusion shall be 11 gauge ( $\frac{1}{8}"$ ) wall thickness with no warping or mold shifting. Electrical wiring shall run through arm up and out through the  $\approx 2 \frac{5}{8}"$  opening.

**ELECTRICAL**

All electrical wiring is ran through center shaft and arm and shall be UL-recognized and wired by a certified UL technician. The electrical assembly is prewired with quick disconnects for servicing. Fixture shall be UL certified for wet locations.

**MOUNTING**

Arm shall be mounted to a (2)  $3\frac{3}{4}"$ W.x  $7\frac{1}{2}"$ H.x  $1\frac{1}{2}"$ D. arm bracket using (3) steel hex head set screws for fastening.

**FINISH**

Fixture finish shall consist of degreasing, phosphate acid etching with 140+ deionized water, rinsed, oven dry off and top coated with a thermoset TGIC super polyester powder coat finish designed not to chalk or fade for many years. All Niland Company powders must pass a minimum 3000-hour salt spray test for corrosion resistance.

**CERTIFICATION**

The Fixture shall be UL-Listed for wet location use, and all HID listings.

**WARRANTY**

Fixture shall be warranted to be free of defects for five years. Ballast components shall carry the ballast manufacturers limited warranty of two years.

Catalog Name: GTW-20-TSS-23.25-DAV-2-BY-19-FLAT Date: 02.15.18

Revision History: N/A Revision #: 0

Niland Approval: Luis M. Gomez Customer Approval: \_\_\_\_\_ Page: 4 of 5



# Niland Company

NILAND COMPANY      • PH: (915) 779-1405 • FAX: (915) 779-3618 • E-MAIL: INFO@NILANDCO.COM  
 320 N. Clark El Paso, Tx 79905 • PH: 800-648-9013 • FAX: 888-779-3065 • WEB PAGE: HTTP://www.nilandco.com

FULL CUT OFF  
DARK SKY COMPLIANT:  
HORIZONTAL REFLECTOR WITH  
TYPE III OR V DISTRIBUTION,  
FLAT TEMPERED GLASS

# BAYSIDE SERIES

## BY-19-H-FLAT

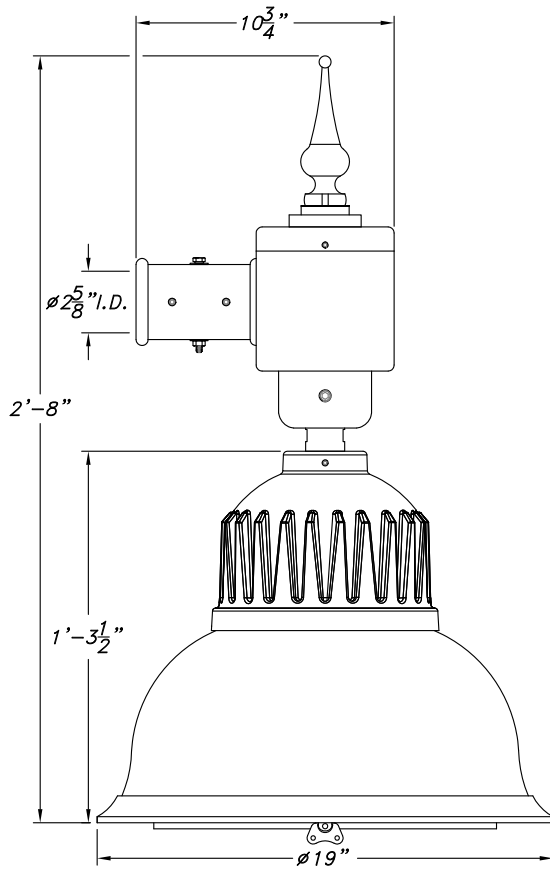

SCALE: 1"=1'-0"

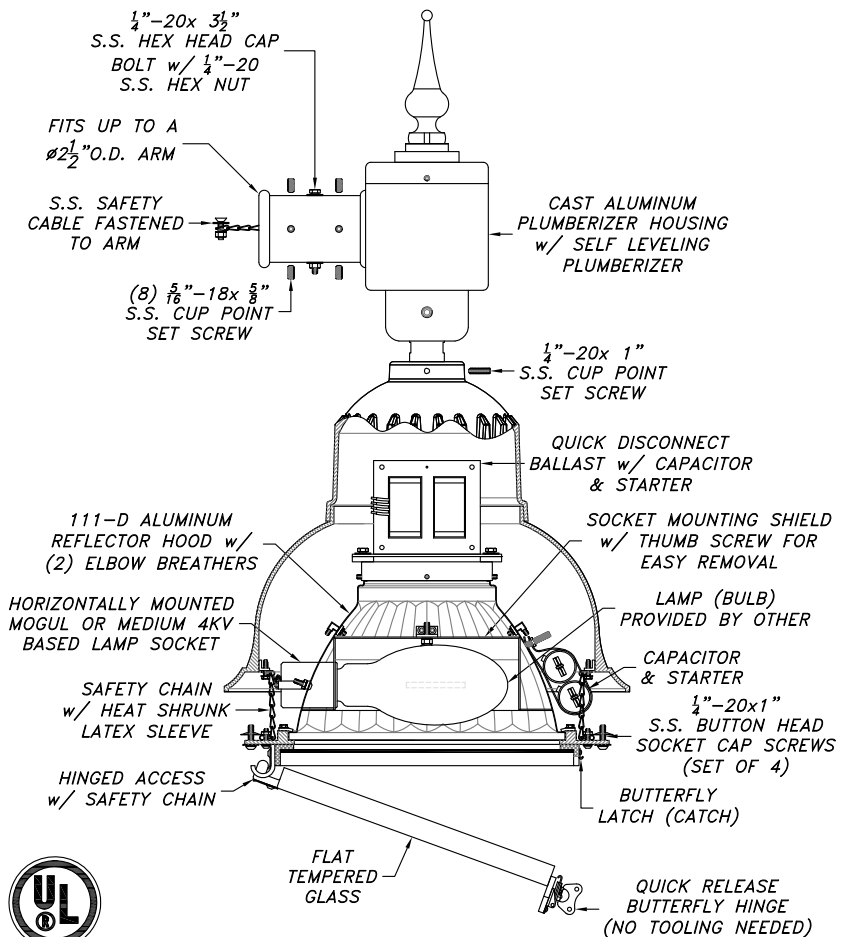

**EXAMPLE**

BY-19-H-FLAT-PSMH-150-208-III-BLK

BY-19-H-FLAT-\_\_\_\_\_-\_\_\_\_\_-\_\_\_\_\_-\_\_\_\_\_-\_\_\_\_\_-\_\_\_\_\_-  
 Series Ballast Wattage Voltage Distribution Color

LIGHT SOURCE	WATTAGE-SOCKET MEDIUM MOGUL	VOLTAGE	LIGHT DISTRIBUTION	COLOR OF POWDER COAT FINISH	
<input type="checkbox"/> INC <input type="checkbox"/> CFL <input type="checkbox"/> HPS <input type="checkbox"/> PSMH <input type="checkbox"/> LED	<input type="checkbox"/> 50w <input type="checkbox"/> 70w <input type="checkbox"/> 100w <input type="checkbox"/> 150w <input type="checkbox"/> 175w <input type="checkbox"/> 250w	<input type="checkbox"/> 120v <input type="checkbox"/> 208v <input type="checkbox"/> 240v <input type="checkbox"/> 277v <input type="checkbox"/> 480v MULTITAP 120v 240v 208v 277v PLEASE SPECIFY VOLTAGE	<input type="checkbox"/> TYPE III <input type="checkbox"/> TYPE V	<input type="checkbox"/> (BLK) BLACK <input type="checkbox"/> (BRZ) BRONZE <input type="checkbox"/> (GRN) GREEN	<input type="checkbox"/> (HG) HAND BRUSHED GREEN <input type="checkbox"/> (HR) HAND BRUSHED GRAY <input type="checkbox"/> CUSTOM _____

### LUMINAIRE SPECIFICATION

**HOUSING**

The pendant mount luminaire shall be core cast aluminum. Aluminum shall be certified as pure #356 alloy, free of any porosity, foreign materials or cosmetic fillers. Castings shall be uniform wall thickness with no warping or mold shifting. Minimum wall thickness shall be 3/16". Electrical components are mounted in the pendant luminaire with two stainless steel screws. 111-D reflector is designed for a Type III or V light distribution pattern. The reflector shall be mounted in the luminaire with four S.S. Screws.

**ELECTRICAL**

All electrical components and materials shall be UL-recognized and wired by a certified UL technician. All Niland ballasts are high power factor rated for -30°C/-20°F starting. Medium and Mogul base sockets are 4 KV rated. The electrical assembly is prewired with quick disconnects for servicing. Fixture shall be UL certified for wet locations.

**MOUNTING**

Fixture shall be mounted to a Self Leveling Plumberizer. Plumberizer shall mount to arm with stainless steel set screws and thru bolt.

**RELAMPING**

To relamp, loosen S.S. Button Head Screws and lower Mounting Ring to access reflector socket.

**FINISH**

Fixture finish shall consist of degreasing, phosphate acid etching with 140+ deionized water, rinsed, oven dry off and top coated with a thermoset TGIC super polyester powder coat finish designed not to chalk or fade for many years. All Niland Company powders must pass a minimum 3000-hour salt spray test for corrosion resistance.

**CERTIFICATION**

The Fixture shall be UL-Listed for wet location use, and all HID listings.

**WARRANTY**

Fixture shall be warranted to be free of defects for five years. Ballast components shall carry the ballast manufacturers limited warranty of two years.

**PHOTOMETRICS**

Complete photometric data for all fixtures is available in IES-formatted 3.5 disks. A certified independent laboratory performs all testing. Call the Niland Company directly for more information.

Catalog Name: GTW-20-TSS-23.25-DAV-2-BY-19-H-FLAT Date: 02.15.18  
 Revision History: N/A Revision #: 0



# Niland Company

Niland Approval: Luis M. Gomez Customer Approval: \_\_\_\_\_ Page: 5 of 5

NILAND COMPANY • PH: (915) 779-1405 • FAX: (915) 779-3618 • E-MAIL: INFO@NILANDCO.COM  
 320 N. Clark El Paso, Tx 79905 • PH: 800-648-9013 • FAX: 888-779-3065 • WEB PAGE: HTTP://www.nilandco.com