

CUT OFF LANTERN:
DARK SKY COMPLIANT, PENDANT
MOUNTED HORIZONTAL LED
ASSEMBLY, TYPE III OR V
DISTRIBUTION, TEMPERED GLOBE

BOSTON COMMON LED SERIES

BC-20-LEX-LED-S7

IP 66 RATED
LED CHAMBER

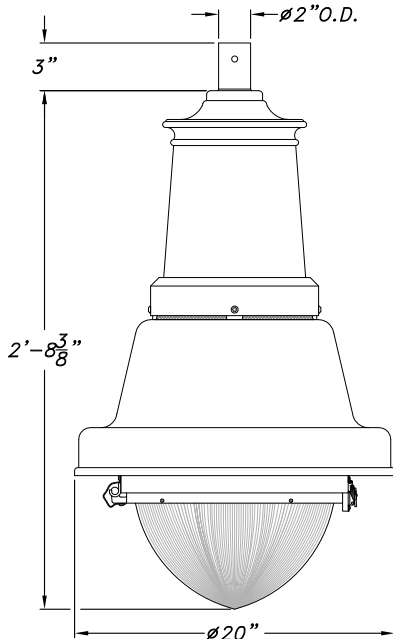

SCALE: 1"=1'-0"

E.P.A.=2.42 SQ.FT.

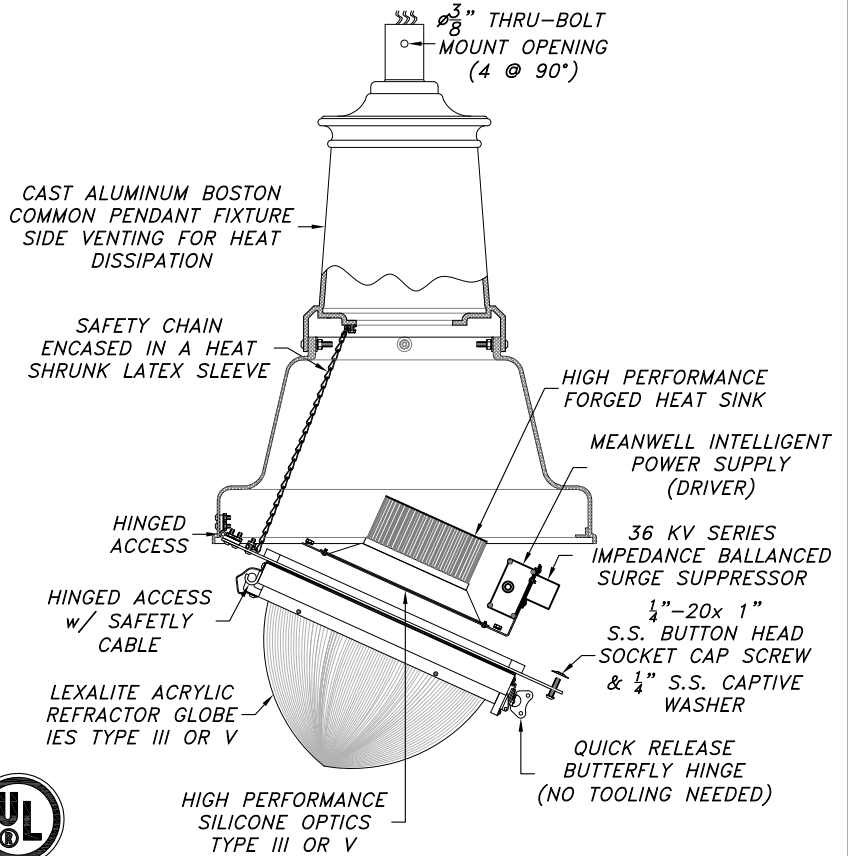

EXAMPLE

BC-20-LEX-LED-5000-115-120/277-III-BLK

BC-20-LEX-LED- _____
 Series Kelvin Wattage Voltage Distribution Color

STANDARD KELVIN	WATTAGE RANGE ACTUAL = EQUIVALENT = LUMENS	VOLTAGE RANGE-AC	LIGHT DISTRIBUTION	COLOR OF POWDER COAT FINISH
<input type="checkbox"/> 3000 <input type="checkbox"/> 4000 <input type="checkbox"/> 5000	<input type="checkbox"/> 60w=100w HPS/150w MH EQ.- 7,400 Lmns <input type="checkbox"/> 80w=150w HPS/250w MH EQ.- 9,800 Lmns <input type="checkbox"/> 115w=200w HPS/320w MH EQ.-12,800 Lmns <input type="checkbox"/> 140w=250w HPS/400w MH EQ.-15,800 Lmns <input type="checkbox"/> 240w=400w HPS/750w MH EQ.-28,300 Lmns	120/277v	<input type="checkbox"/> TYPE III <input type="checkbox"/> TYPE V	<input type="checkbox"/> (BLK) BLACK <input type="checkbox"/> (HG) HAND BRUSHED GREEN <input type="checkbox"/> (BRZ) BRONZE <input type="checkbox"/> (HR) HAND BRISHED GRAY <input type="checkbox"/> (GRN) GREEN <input type="checkbox"/> CUSTOM _____

LUMINAIRE SPECIFICATION

HOUSING

The pendant mount luminaire shall be core cast aluminum. Aluminum shall be certified as pure #356 alloy, free of any porosity, foreign materials or cosmetic fillers. Castings shall be uniform wall thickness with no warping or mold shifting. Minimum wall thickness shall be 3/16". Electrical components are one piece plug-in, LED assembly unit shall be mounted with four stainless steel screws. The core ports for ventilation located just beneath pendant housing and LED unit mounting ring increase thermal management and over all LED longevity. A optional refractor globe shall be molded of acrylic with external refractors designed for a Type III or V light distribution pattern.

LED POWER SUPPLY

All electrical components and materials shall be UL-recognized and wired by a certified UL technician. The electrical assembly is prewired with quick disconnects for servicing. Electrical components rated for 1 amp but only draws 300 millamps which adds to the units longevity. Input voltage 120-277v with 36kV surge suppression. All components are IP66 rated with a 1.0 PF rating. Service life up to 100,000 hours life at -40°C to +40°C Ambient, Operating Temperature, <20% Total Harmonic Distortion

LED CIRCUIT BOARD

LED's are available in 3000, 4000 & 5000 Kelvin with a Type III or Type V light distribution. Instant On/Off soft start, PF rating of 95% Solid State panel.

MOUNTING

Fixture shall be mounted to ≈ 2 1/2" O.D. arm with stainless steel thru bolt and allen set screws (3 @ 120°)

CERTIFICATION

The fixture shall be UL Certified for wet location use. LED unit is DLC Listed with IP66 Components. Designed to UL 1598 & UL 1449 3rd Edition. UL Driver is installed. Complies with IEEE C62.41 and FCC Part 15 Class A.

FINISH-AAMA-2604-5

Fixture finish shall consist of degreasing, phosphate acid etching with 140+ deionized water, rinsed, oven dry off and top coated with a thermoset TGIC super polyester powder coat finish designed not to chalk or fade for many years. All Niland Company powders must pass a minimum 3000-hour salt spray test for corrosion resistance.

WARRANTY

Quick 60+ month warranty on LED module and electronic driver. Please contact manufacturer for more details.

PHOTOMETRICS

Complete photometric data for all fixtures is available in IES-formatted. A certified independent laboratory performs all testing. Call the Niland Company directly for more information.

Catalog Name: BC-20-LEX-LED-S7 Date: 03.22.19
 Revision History: N/A Revision # 0

Niland Approval: Luis M.Gomez Customer Approval: _____ Page: 5 of 5



OSRAM SYLVANIA QUICK 60+
Warranty On Parts

NILAND COMPANY • PH: (915) 779-1405 • FAX: (915) 779-3618 • E-MAIL: INFO@NILANDCO.COM
 320 N. Clark El Paso, Tx 79905 • PH: 800-648-9013 • FAX: 888-779-3065 • WEB PAGE: HTTP://www.nilandco.com