

GENEVA SERIES

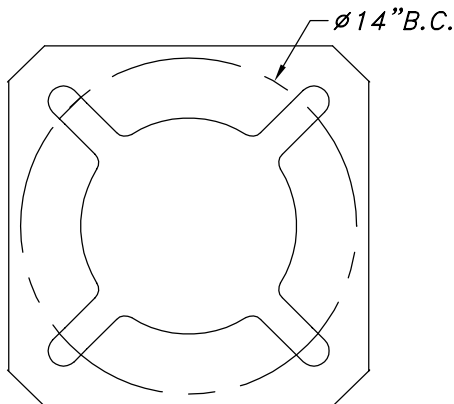
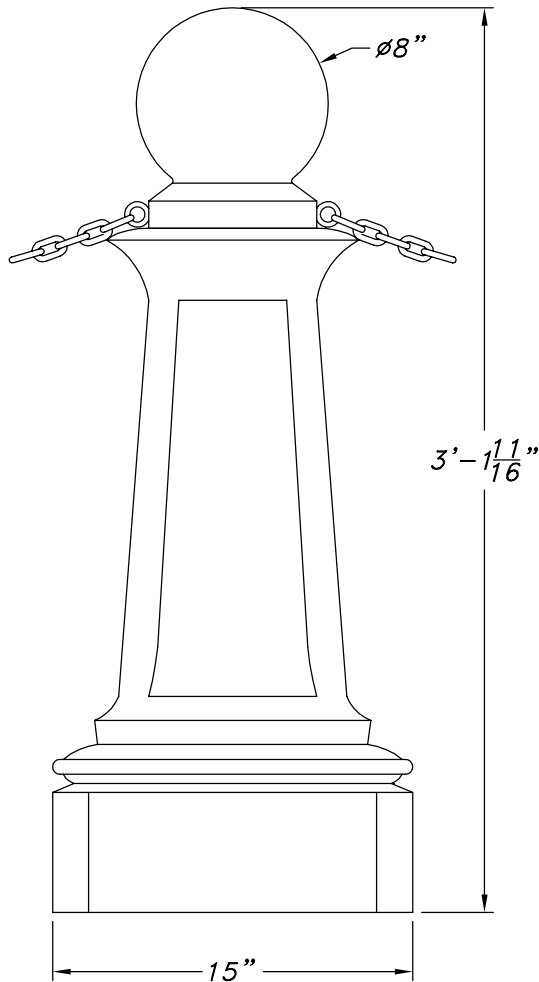

SCALE: 1 1/2" = 1'-0"

GV-BOLLARD-BT

CSI POLE SPECIFICATION

I. POLE

Base shall be cast aluminum. Aluminum shall be certified as pure 356 alloy free of any porosity, foreign materials or cosmetic fillers. Base casting shall be of uniform wall thickness with no warping or mold shifting. Minimum wall thickness shall be .250". The base casting shall have an internal sleeve up to 25" deep (depending on style chosen) to accept the pole shaft. Pole shaft shall be seated into the base sleeve and circumferentially welded around the inside of the base. Exterior transition ring shall be cast in to the top of the base to mirror the design of the fluted shaft. There are no exterior welds to finish. The anchor bolt locations in the base shall be cast in place as part of the base casting, for maximum strength. Pole shaft shall be seamless, deep-fluted extruded 6063-T6 aluminum. Cast aluminum access cover shall be secured with two to four tamper proof stainless steel screws.

II. FINISH

Fixture finish shall consist of degreasing, phosphate acid etching with 140°+ de-ionizing water, rinsed, oven dryoff and top coated with a thermoset TGIC super polyester powder coat finish designed not to chalk or fade for many years. All Niland Company powders must pass a minimum 3000-hour salt spray test for corrosion resistance.

III. ANCHOR BOLTS

Standards 12 feet high or less shall use 1/2" x 18" L-type anchor bolts. Standards higher than 12 feet shall use 3/4" x 24" L-type bolts.

FINISHES

Five Year Powder Coating Warranty

Niland Company factory-applied powder coatings are warranted against peeling, excessive fading and cracking under normal climatic exposure for a period of five years from date of shipment. Damage to finish coating caused by abuse or mishandling during installation is not covered by this warranty. This warranty is limited to the repair or replacement of the material involved and does not include reimbursement of consequential expenses such as installation or removal of equipment or transportation costs.

I. STANDARD FINISH

Satin aluminum achieved by rotary sanding, blasting and chemical etching.

II. THERMOSET POWDER PAINT FINISH

Pretreatment shall consist of degreasing phosphate acid-etching with 140° and de-ionizing water, rinsed and oven dried.

FINISH COAT

Thermoset TGIC super polyester powder coat finish electrostatically applied, oven cured and bonded at approximately 420° F to a minimum dry film thickness of 1.6 mils. All Niland powders must pass a minimum 3000-hour salt-spray test for corrosion resistance. The National Association of Architectural Metal Manufacturers, Metal Finishes Manual rates the outdoor life of these powders at 15-plus years.

HOUSING

The post top shall be core cast aluminum. Aluminum shall be certified as pure #356 alloy, free of any porosity, foreign materials or cosmetic fillers. Castings shall be uniform wall thickness with no warping or mold shifting. Minimum wall thickness shall be 3/16". Electrical components are mounted to the fitter and ballast canister. The ballast canister shall be mounted in the post top with three stainless steel screws. The optional refractor shall be molded of borosilicate glass or an upgraded globe with external refractor designed for either a type III or type V light distribution pattern.

III. ELECTRICAL

All electrical components and materials shall be UL-recognized and wired by a certified UL technician. All Niland ballasts are high power factor rated for 30°C/-20°F starting. Medium and Mogul base sockets are 5KV rated. The electrical assembly is prewired with quick disconnects for servicing. Fixture shall be UL certified for wet locations and carry all HID listings required. Ballast components shall carry the ballast manufacturers limited warranty of two years. Optional QL Induction ballasts and lamps.

WARRANTY

Niland Company warrants to repair or replace, at our option, any equipment that fails due to defects in material or workmanship within one year from date of shipment. This warranty does not include failures as a result of improper installation, mishandling or misapplication. This guarantee is limited to repair or replacement only and does not include reimbursement for expense of installation, removal of equipment, transportation or any other expenses that may be incurred. Authorization must be obtained from Niland Company in El Paso, Texas before any material is returned.



Niland Company

NILAND COMPANY • PH: (915) 779-1405 • FAX: (915) 779-3618 • E-MAIL: INFO@NILANDCO.COM
320 N. Clark El Paso, Tx 79905 • PH: 800-648-9013 • FAX: 888-779-3065 • WEB PAGE: HTTP://www.nilandco.com