

PLAZA LED SERIES

PZ-5015-BAND-LED-D4

IP66 RATED
COMPONENTS

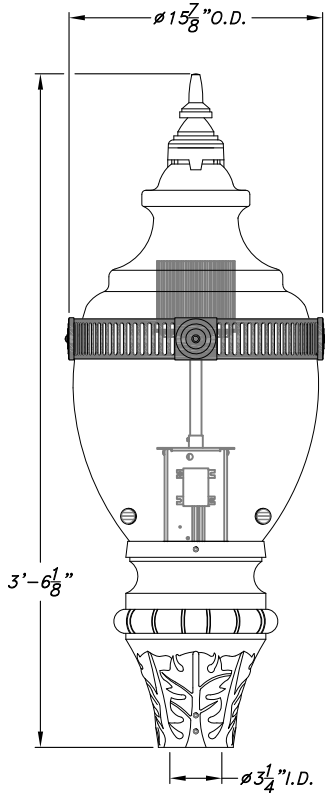

SCALE: 1"=1'-0"

E.P.A.=2.6 SQ.FT.

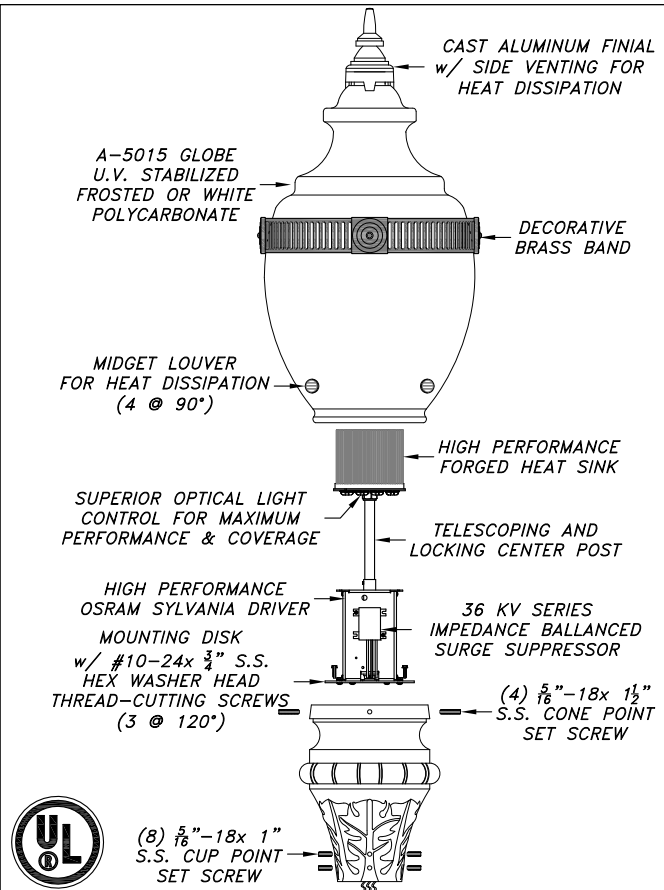

(8) 5/16" - 18 x 1" S.S. CUP POINT SET SCREW

EXAMPLE

PZ-5015-BAND-LED-5000-60-120/277-III-BLK

PZ-5015-BAND-LED-

Series Globe Kelvin Wattage Voltage Distribution Color

GLOBE	KELVIN	MODEL# = WATTAGE = LUMENS				VOLTAGE RANGE-AC	LIGHT DISTRIBUTION	COLOR OF POWDER COAT FINISH	
		#30=30W	#40=38W	#60=57W	#80=77w				
<input type="checkbox"/> FROSTED (CLEAR)	<input type="checkbox"/> 2200	<input type="checkbox"/> 3372Lmns	<input type="checkbox"/> 4196Lmns	<input type="checkbox"/> 6387Lmns	<input type="checkbox"/> 8017Lmns	120/277V	<input type="checkbox"/> TYPE III <input type="checkbox"/> TYPE V	<input type="checkbox"/> (BLK) BLACK	<input type="checkbox"/> (HG) HAND BRUSHED GREEN
	<input type="checkbox"/> 3000	<input type="checkbox"/> 3853Lmns	<input type="checkbox"/> 4675Lmns	<input type="checkbox"/> 6464Lmns	<input type="checkbox"/> 8050Lmns			<input type="checkbox"/> (BRZ) BRONZE	<input type="checkbox"/> (HR) HAND BRUSHED GRAY
<input type="checkbox"/> WHITE (MILKY)	<input type="checkbox"/> 4000	<input type="checkbox"/> 4095Lmns	<input type="checkbox"/> 4969Lmns	<input type="checkbox"/> 6870Lmns	<input type="checkbox"/> 8556Lmns			<input type="checkbox"/> (GRN) GREEN	<input type="checkbox"/> CUSTOM _____
	<input type="checkbox"/> 5000	<input type="checkbox"/> 4095Lmns	<input type="checkbox"/> 4969Lmns	<input type="checkbox"/> 6870Lmns	<input type="checkbox"/> 8556Lmns				

LUMINAIRE SPECIFICATION

HOUSING

The post top shall be core cast aluminum. Aluminum shall be certified as pure #356 alloy, free of any porosity, foreign materials or cosmetic fillers. Castings shall be uniform wall thickness with no warping or mold shifting. Minimum wall thickness shall be 3/16". LED assembly unit shall be mounted in the post top with four stainless steel screws and a quick disconnect for easy removal. Heat vents at base of finial at top of globe increases thermal management and LED longevity.

LED POWER SUPPLY

All electrical components and materials shall be UL-recognized and wired by a certified UL technician. The electrical assembly is prewired with quick disconnects for servicing. Electrical components rated for 1 amp but only draws 300 millamps which adds to the units longevity. Input voltage 120-277v with 36kV surge suppression. All components are IP66 rated with a 1.0 PF rating. Service life up to 100,000 hours life at -40°C to +40°C Ambient, Operating Temperature. <20% Total Harmonic Distortion

LED CIRCUIT BOARD

LED's are available in 2200, 3000, 4000 & 5000 Kelvin with a Type III or Type V light distribution. Instant On/Off soft start. PF rating of 92% Solid State panel.

MOUNTING

Fixture shall be mounted to 3"O.D.x3"H, tenon with stainless steel allen head set screws (8 @ 90°)

CERTIFICATION

The fixture shall be UL Certified for wet location use. LED unit is DLC Listed with IP66 Components. Designed to UL 1598 & UL 1449 3rd Edition. UL Driver is installed. Complies with IEEE C62.41 and FCC Part 15 Class A.

FINISH-AAMA-2604-5

Fixture finish shall consist of degreasing, phosphate acid etching with 140+ deionized water, rinsed, oven dry off and top coated with a thermoset TGIC super polyester powder coat finish designed not to chalk or fade for many years. All Niland Company powders must pass a minimum 3000-hour salt spray test for corrosion resistance.

WARRANTY

Quick 60+ month warranty on LED module and electronic driver. Please contact manufacturer for more details.

PHOTOMETRICS

Complete photometric data for all fixtures is available in IES-formatted. A certified independent laboratory performs all testing. Call the Niland Company directly for more information.

Catalog Name: PZ-5015-BAND-LED-D4 Date: 03.22.19

Revision History: N/A Revision #: 0

Niland Approval: Luis M. Gomez Customer Approval: _____ Page: 3 of 3



OSRAM SYLVANIA QUICK 60+
Warranty On Parts

NILAND COMPANY • PH: (915) 779-1405 • FAX: (915) 779-3618 • E-MAIL: INFO@NILANDCO.COM
320 N. Clark El Paso, Tx 79905 • PH: 800-648-9013 • FAX: 888-779-3065 • WEB PAGE: HTTP://www.nilandco.com