

WESTPOINT SERIES

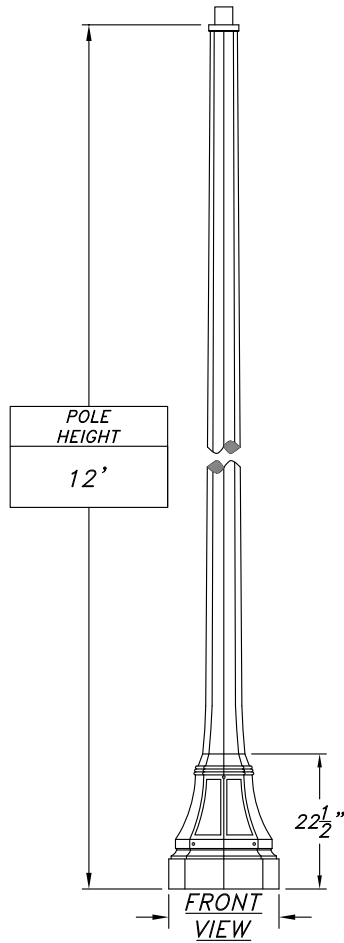

SCALE: 3/8" = 1'-0"

WP-17-OCT-12

4.5"-5.75" dia. cast aluminum tapered octagonal shaft
12' in height

CSI POLE SPECIFICATION

I. BASE/POLE

Base/Pole shall be cast aluminum. Aluminum shall be certified as pure 356 copper free of any porosity, foreign materials or cosmetic fillers. Base casting shall be of uniform wall thickness with no warping or mold shifting. Minimum wall thickness shall be .250". Cast aluminum access cover shall be secured with two stainless steel screws. The anchor bolt locations in the base shall be cast in place as part of the base casting, for maximum strength. Luminaire shall be mounted to pole with a $\approx 3^{\circ}$ O.D. x3"H. tenon.

II. ANCHORAGE DETAIL

Standards 3/4" x 24" L-type bolts shall be used for installation.

WARRANTY

Niland Company warrants to repair or replace, at our option, any equipment that fails due to defects in material or workmanship within one year from date of shipment. This warranty does not include failures as a result of improper installation, mishandling or misapplication. This guarantee is limited to repair or replacement only and does not include reimbursement for expense of installation, removal of equipment, transportation or any other expenses that may be incurred. Authorization must be obtained from Niland Company in El Paso, Texas before any material is returned.

FINISHES

Five Year Powder Coating Warranty

Niland Company factory-applied powder coatings are warranted against peeling, excessive fading and cracking under normal climatic exposure for a period of five years from date of shipment. Damage to finish coating caused by abuse or mishandling during installation is not covered by warranty. This warranty is limited to the repair or replacement of the material involved and does not include reimbursement of consequential expenses such as installation or removal of equipment or transportation costs.

I. STANDARD FINISH

Satin iron achieved by rotary sanding, blasting and phosphate conversion coating.

II. THERMOSET POWDER PAINT FINISH

Pretreatment shall consist of degreasing phosphate acid-etching with 140° and de-ionizing water, rinsed and oven dried.

FINISH COAT

Thermoset TGIC super polyester powder coat finish electrostatically applied, oven cured and bonded at approximately 420° F to a minimum dry film thickness of 1.6 mils. All Niland powders must pass a minimum 3000-hour salt-spray test for corrosion resistance. The National Association of Architectural Metal Manufacturers, Metal Finishes Manual rates the outdoor life of these powders at 15-plus years.

III. LIQUID FINISH

Optional liquid finish is first prime coated then finished with a two part liquid epoxy coat.

Revision #: 0 Date: 02.15.18 Page: 1 of 2
 Revision History: N/A

 Niland Approval: Luis M. Gomez Customer Approval: _____



Niland Company

NILAND COMPANY • PH: (915) 779-1405 • FAX: (915) 779-3618 • E-MAIL: INFO@NILANDCO.COM
 320 N. Clark El Paso, Tx 79905 • PH: 800-648-9013 • FAX: 888-779-3065 • WEB PAGE: HTTP://www.nilandco.com

WESTPOINT SERIES

CAST POLE & BASE

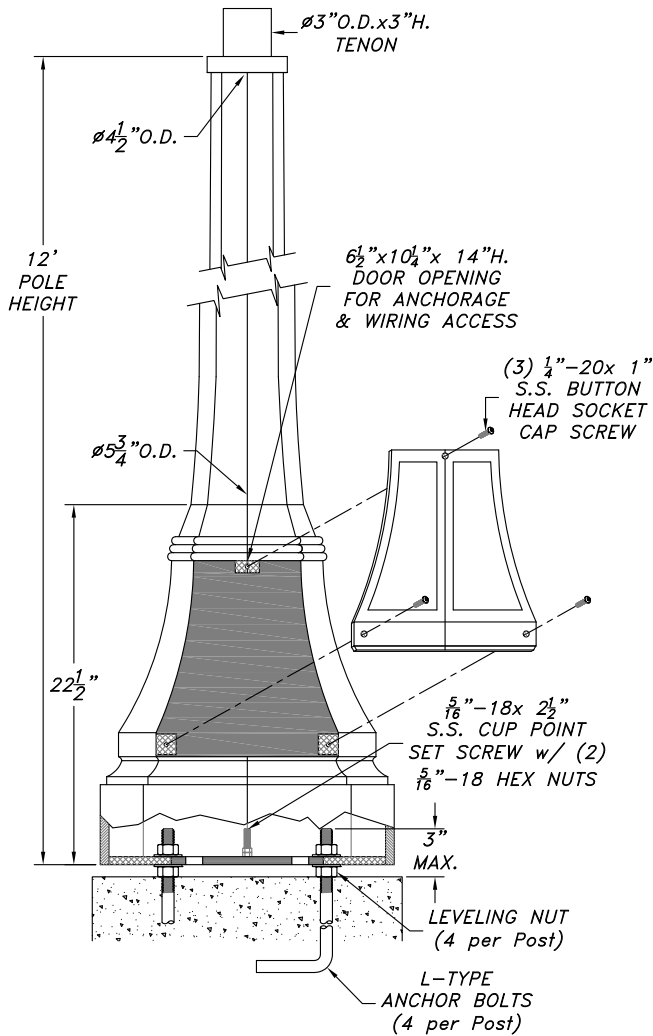

ANCHOR BOLT CIRCLE DIAMETER

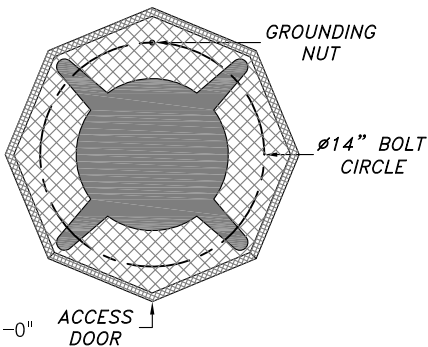

SCALE: 1"=1'-0"

Core Cast Westpoint Series-17" Base-Tapered Octagonal-12' Height
WP-17-OCT-12

Catalog Name: WP-17-OCT-12-Spec Date: 02.15.18
Revision History: N/A Revision #: 0

Niland Approval: Luis M. Gomez Customer Approval: _____ Page: 2 of 3

ORDERING GUIDE

Catalog Code Description: WP-17-OCT-12-top-globe

Name of Base (Westpoint): Diameter of Base (17")
Type of Pole (Tapered Octagonal); Height of Pole (12')
Top Style (None); Color (None); Optional Equip. (None)

Post Selection:

Specify pole height from bottom of base.

Catalog Code	Shaft Type	Height
WP-17-OCT-12	4.5"-5.75" tapered octagonal	12'

Check Appropriate Boxes for Material

Cast Aluminum

Shaft Options

1/4" Extrusion

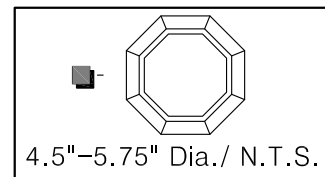

Optional Pole Accessories

- GFI Receptacles (See Accessories Section)
- Banner Arms (See Accessories Section)
- Flag Pole Holders (See Accessories Section)
- Signage (See Accessories Section)

Check Appropriate Boxes for Finish

- Black
- Bronze
- Green
- Hand Brushed Green
- Hand Brushed Gray
- Custom _____

Ordering Instructions

To order, simply follow the format for the Catalog Code. Once the base has been selected, use the base initials to begin your catalog code. The next entry on the code is the diameter of the base. Next, you will choose the type of pole that the product will have whether it is smooth, fluted, tapered fluted etc. The height of the pole is next and it is measured from the bottom of the base. The post top style is next and followed by the globe type. Codes can be found under each item.

The code description is:

Base Series-Diameter-Pole Shaft-Height-Top-Globe.



Niland Company