

# Cobra Head LED Series

## CE-LED

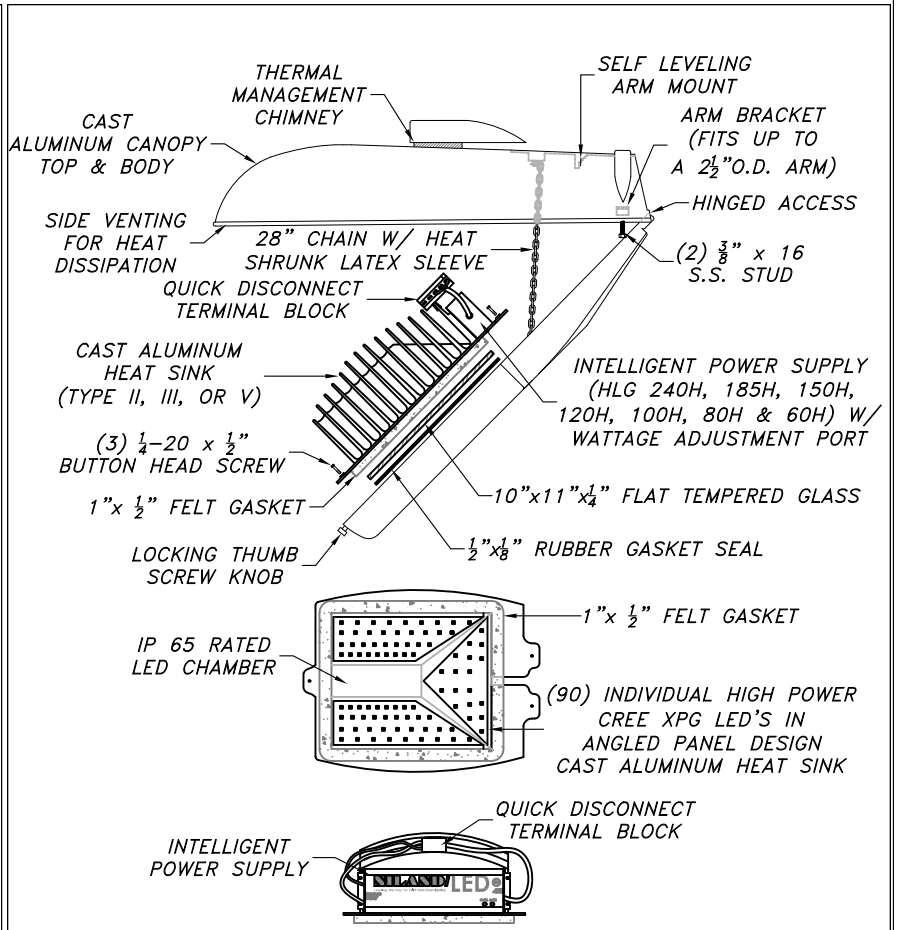
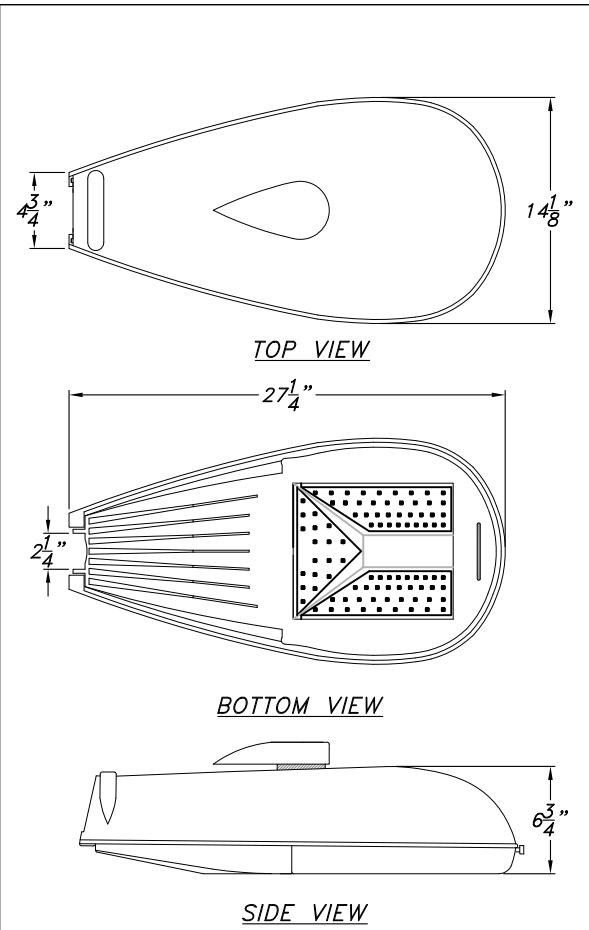

E.P.A. = 1.17 SQ. FT.

SCALE: 1" = 1'-0"

SCALE: 1" = 1'-0"

STANDARD KELVINS	WATTAGE RANGE	VOLTAGE RANGE	LIGHT DISTRIBUTION	COLOR (POWDER COATED)	
3500 <input type="checkbox"/> (WARM WHITE)	WATTAGE ADJUSTABLE 25-125 WATTS	90-305VAC <input type="checkbox"/>	TYPE II <input type="checkbox"/>	(TB) TEXTURED BLACK <input type="checkbox"/>	(GB) GLOSS BLACK <input type="checkbox"/>
5000 <input type="checkbox"/> (BRIGHT WHITE)		480VAC <input type="checkbox"/>	TYPE III <input type="checkbox"/>	(TG) TEXTURED FOREST GREEN <input type="checkbox"/>	(GG) GLOSS GREEN <input type="checkbox"/>
	**FACTORY PRESET TO 125W (250W HID EQ.)**		TYPE V <input type="checkbox"/>	(TR) TEXTURED BRONZE <input type="checkbox"/>	(GR) GLOSS BRONZE <input type="checkbox"/>
				(HG) HAND BRUSHED GREEN <input type="checkbox"/>	CUSTOM _____ <input type="checkbox"/>
				(HR) HAND BRUSHED GRAY <input type="checkbox"/>	

LED OPTIONS (NOT STANDARD)  ADDITIONAL KELVINS (COLORS) AVAILABLE \_\_\_\_\_

### LUMINAIRE SPECIFICATIONS

**HOUSING**  
The fixture shall be core cast aluminum. Aluminum shall be certified as pure #356 alloy, free of any porosity, foreign materials or cosmetic fillers. Castings shall be uniform wall thickness with no warping or mold shifting. Minimum wall thickness shall be 3/16". Electrical components are one piece plug-in. LED assembly unit shall be mounted with four stainless steel screws. The core ports for ventilation located just beneath canopy and fixture finial increase thermal management and over all LED longevity.

**LED POWER SUPPLY**  
Up to 100,000 hours Mean Time Before Failure (MTBF). Each factor adjustable setting draws between 300 to 600 milliamps of power. Only 1 power supply is used for up to 125 LED watts each enclosed fixture. Multiple circuit detection and protections. Each unit is rated up to 16 amps of power. Input voltage range of 90-305VAC. Minimum operating temperature -22°F (-30°C) Maximum operating temperature 140°F (60°C).

**LED CIRCUIT BOARDS**  
90 individual, CREE XPG LED's rated for up to 100,000 hours service life. 5000 Kelvin white LED's are standard with a CRI of 72, 3500 Kelvins "warm white" LED's are optional. Lead free and RoHS compliant.

**MOUNTING**  
Fits 1 1/4" to 2 1/2" diameter O.D. horizontal tenon. Mounted with (4) 3/8" bolts w/ (1) "U"clamps.

**CERTIFICATION**  
The fixture shall be UL Certified for wet location use, and all HID listings.

**FINISH-AAMA-2604-5**  
Fixture finish shall consist of degreasing, phosphate acid etching with 140°+ deionized water, rinsed, oven dry off and top coated with a thermoset TGIC super polyester powder coat finish designed not to chalk or fade for many years. All Niland Company powders must pass a minimum 3000-hour salt spray test for corrosion resistance.

**WARRANTY**  
Quick 60+ month warranty on LED module and electronic driver. Please contact manufacturer for more details.

**PHOTOMETRICS**  
Contact manufacturer for details.



**Leading The Way For Solid State Street Lighting**

**OSRAM SYLVANIA** QUICK 60+ Warranty On Parts and Labor

Niland Approval: \_\_\_\_\_ Customer Approval: \_\_\_\_\_ Page: 1 of 1

Catalog Name: CE-LED \_\_\_\_\_ Date: \_\_\_\_\_  
 Revision History: N/A \_\_\_\_\_ Revision #: 0

NILAND COMPANY • PH: (915) 779-1405 • FAX: (915) 779-3618 • E-MAIL: INFO@NILANDCO.COM  
 320 N. Clark El Paso, Tx 79905 • PH: 800-648-9013 • FAX: 888-779-3065 • WEB PAGE: HTTP://www.nilandco.com