

# NILAND-18 SERIES

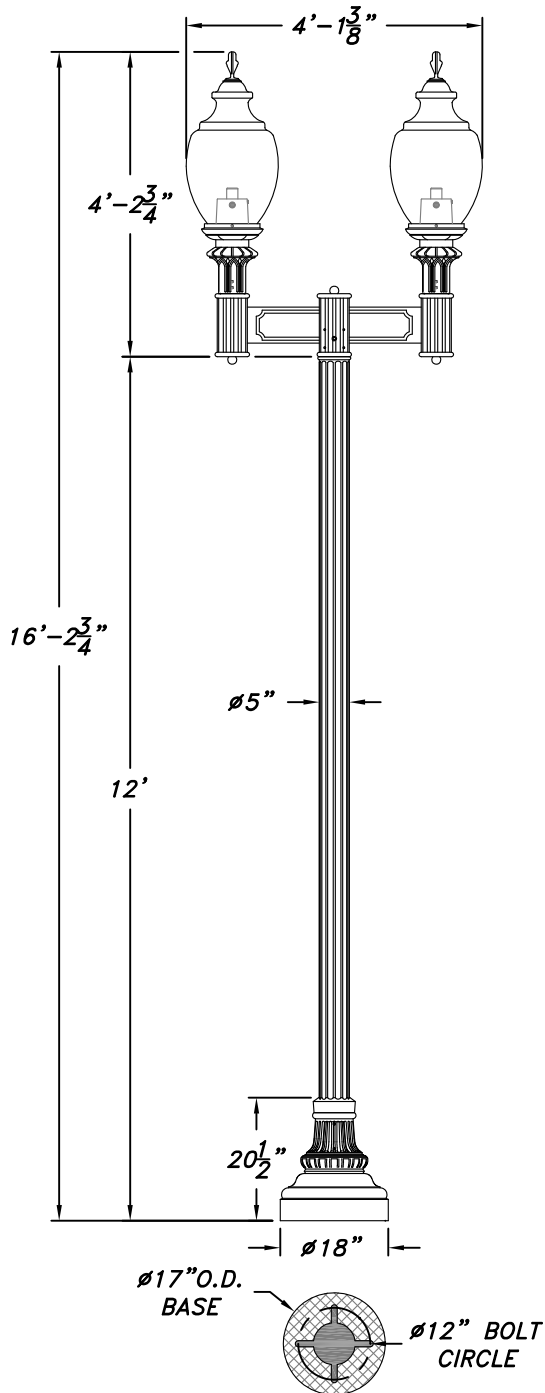

SCALE: 3/8"=1'-0"

Catalog Name:

**N-18-F5-12-DV-2-CP-5015**

Revision # 0

Date: 02.15.18

Page: 1 of 4

Revision History: N/A

Niland Approval: Luis M. Gomez

Customer Approval:

## CSI POLE SPECIFICATION

### I. BASE

Base shall be cast aluminum. Aluminum shall be certified as pure 356 copper free of any porosity, foreign materials or cosmetic fillers. Base casting shall be of uniform wall thickness with no warping or mold shifting. Minimum wall thickness shall be .250". The base casting shall have an internal sleeve up to 25" deep (depending on style chosen) to accept the pole shaft. Cast aluminum access cover shall be secured with two to four stainless steel screws. Exterior transition ring shall be cast in to the top of the base to mirror the design of the smooth or fluted shaft. There are no exterior welds to finish. The anchor bolt locations in the base shall be cast in place as part of the base casting, for maximum strength.

### II. POLE

Pole shaft shall be seated into the base sleeve and circumferentially welded around the inside of the base. Shaft extrusion shall be of uniform wall thickness with no warping or mold shifting. Minimum wall thickness shall be .188" or .250". Exterior transition ring shall be cast in to the top of the base to mirror the design of the fluted shaft. There are no exterior welds to finish. Pole shaft shall be seamless, deep fluted extruded 6063-T6 aluminum.

### III. ANCHORAGE DETAIL

3/4" x 24" L-type bolts shall be used for this pole assembly.

### IV. ARM

The arms shall be core cast aluminum. Aluminum shall be certified as pure #356 alloy, free of any porosity, foreign materials or cosmetic fillers. Castings shall be uniform wall thickness with no warping or mold shifting. Minimum wall thickness shall be 3/16". Electrical wiring shall run through arm up and out through the 3" O.D. x 3" H tenon.

### V. HOUSING

The post top shall be core cast aluminum. Aluminum shall be certified as pure #356 alloy, free of any porosity, foreign materials or cosmetic fillers. Castings shall be uniform wall thickness with no warping or mold shifting. Minimum wall thickness shall be 3/16". Electrical components are mounted in the ballast canister. The ballast canister shall be mounted in the post top with three stainless steel screws. A optional refractor will be a upgrade refractor globe or borosilicate glass refractor designed for either a type III or type V light distribution pattern.

### VI. ELECTRICAL

All electrical components and materials shall be UL-recognized and wired by a certified UL technician. All Niland ballasts are high power factor rated for -30°C/-20°F starting. Medium and Mogul base sockets are 4 KV rated. The electrical assembly is prewired with quick disconnects for servicing. Fixture shall be UL certified for wet locations. Optional LED unit.

## FINISHES

### Five Year Powder Coating Warranty

Niland Company factory-applied powder coatings are warranted against peeling, excessive fading and cracking under normal climatic exposure for a period of five years from date of shipment. Damage to finish coating caused by abuse or mishandling during installation is not covered by warranty. This warranty is limited to the repair or replacement of the material involved and does not include reimbursement of consequential expenses such as installation or removal of equipment or transportation costs.

### I. STANDARD FINISH

Satin iron achieved by rotary sanding, blasting and phosphate conversion coating.

### II. THERMOSET POWDER PAINT FINISH

Pretreatment shall consist of degreasing phosphate acid-etching with 140° and de-ionizing water, rinsed and oven dried.

### FINISH COAT

Thermoset TGIC super polyester powder coat finish electrostatically applied, oven cured and bonded at approximately 420° F to a minimum dry film thickness of 1.6 mils. All Niland powders must pass a minimum 3000-hour salt-spray test for corrosion resistance. The National Association of Architectural Metal Manufacturers, Metal Finishes Manual rates the outdoor life of these powders at 15-plus years.

### III. LIQUID FINISH

Optional liquid finish is first prime coated then finished with a two part liquid epoxy coat.

### WARRANTY

Niland Company warrants to repair or replace, at our option, any equipment that fails due to defects in material or workmanship within one year from date of shipment. This warranty does not include failures as a result of improper installation, mishandling or misapplication. This guarantee is limited to repair or replacement only and does not include reimbursement for expense of installation, removal of equipment, transportation or any other expenses that may be incurred. Authorization must be obtained from Niland Company in El Paso, Texas before any material is returned.



# Niland Company

NILAND COMPANY • PH: (915) 779-1405 • FAX: (915) 779-3618 • E-MAIL: INFO@NILANDCO.COM  
320 N. Clark El Paso, Tx 79905 • PH: 800-648-9013 • FAX: 888-779-3065 • WEB PAGE: HTTP://www.nilandco.com

# NILAND-18 SERIES

# ORDERING GUIDE

Catalog Code Description: N-18-5-ht-top-globe

Name of Base (Niland); Diameter of Base (18")  
 Type of Pole (Fluted 5"); Height of Pole (None)  
 Top Style (None); Color (None); Optional Equip. (None)

### Post Selection:

Specify pole height from bottom of base.

Catalog Code	Shaft Type	Height
N-18-S5-__	5" dia. smooth	8'-16'
N-18-F5-__	5" dia. fluted	8'-16'
N-18-TF35-__	3"-5" tapered-fluted	8'-16'

### Check Appropriate Boxes for Material

Cast Aluminum

### Shaft Options

1/8" Extrusion       1/4" Extrusion

5" Dia. Smooth       5" Dia. Fluted       3"-5" Dia./ N.T.S.

### Optional Pole Accessories

- GFI Receptacles (See Accessories Section)
- Banner Arms (See Accessories Section)
- Flag Pole Holders (See Accessories Section)
- Signage (See Accessories Section)

### Check Appropriate Boxes for Finish

- Black
- Hand Brushed Green
- Bronze
- Hand Brushed Gray
- Green
- Custom \_\_\_\_\_

### Ordering Instructions

To order, simply follow the format for the Catalog Code. Once the base has been selected, use the base initials to begin your catalog code. The next entry on the code is the diameter of the base. Next, you will choose the type of pole that the product will have whether it is smooth, fluted, tapered fluted etc. The height of the pole is next and it is measured from the bottom of the base. The post top style is next and followed by the globe type. Codes can be found under each item.

The code description is:

Base Series-Diameter-Pole Shaft-Height-Top-Globe.

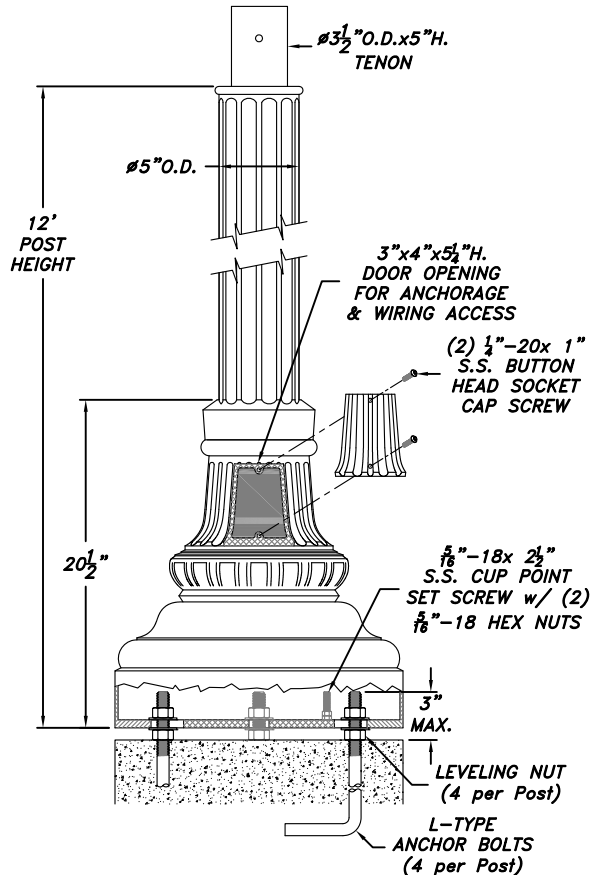

### ANCHOR BOLT CIRCLE DIAMETER

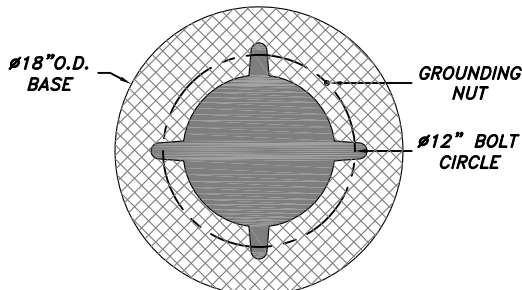

SCALE: 1"=1'-0"

Niland Series-18" Base-Fluted 5"-12' Height  
 N-18-F5-12

Catalog Name: N-18-F5-12-DV-2-CP-5015      Date: 02.15.18  
 Revision History: N/A      Revision #: 0

Niland Approval: Luis M. Gomez      Customer Approval: \_\_\_\_\_      Page: 2 of 4



# Niland Company

# DENVER SERIES

## DV-2

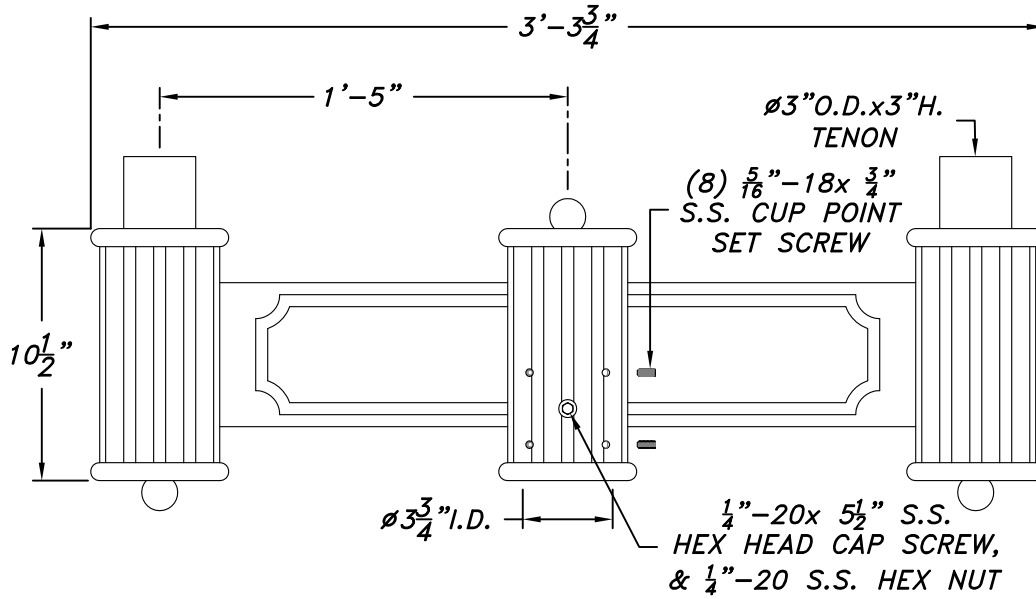

**ARM ORIENTATION**

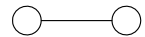

SCALE: 1 1/2"=1'-0"

EXAMPLE  
DV-2-BLK

DV-\_\_\_\_\_ - 2 - \_\_\_\_\_  
Series Mounting Arms Color

### TENON MOUNT ARMS

- DV-1
- DV-2
- DV-3
- DV-4

### w/ CENTER MOUNT

- DV-2C
- DV-3C
- DV-4C

### SIDE MOUNT ARMS

- DV-SM-1
- DV-SM-2
- DV-SM-3
- DV-SM-4

### COLOR OF POWDER COAT FINISH

- |                                       |  |
|---------------------------------------|--|
| <input type="checkbox"/> (BLK) BLACK  | <input type="checkbox"/> (HG) HAND BRUSHED GREEN |
| <input type="checkbox"/> (BRZ) BRONZE | <input type="checkbox"/> (HR) HAND BRUSHED GRAY  |
| <input type="checkbox"/> (GRN) GREEN  | <input type="checkbox"/> CUSTOM _____            |

## ARM SPECIFICATION

#### ARM

The arms shall be core cast aluminum. Aluminum shall be certified as pure #356 alloy, free of any porosity, foreign materials or cosmetic fillers. Castings shall be uniform wall thickness with no warping or mold shifting. Minimum wall thickness shall be 3/16". Electrical wiring shall run through arm up and out through the  $\phi 3''$ O.D.x3"H tenon.

#### ELECTRICAL

All electrical components and materials shall be UL-recognized and wired by a certified UL technician. Arm shall be UL certified for wet locations.

#### MOUNTING

Fixture shall be mounted to  $\phi 3\frac{3}{4}''$ O.D.x5"H. tenon with S.S. Allen Head Set Screws (8 @ 90°)

#### FINISH

Fixture finish shall consist of degreasing, phosphate acid etching with 140+ deionized water, rinsed, oven dry off and top coated with a thermoset TGIC super polyester powder coat finish designed not to chalk or fade for many years. All Niland Company powders must pass a minimum 3000-hour salt spray test for corrosion resistance.

#### CERTIFICATION

The Fixture shall be UL-Listed for wet location use, and all HID listings.

#### WARRANTY

Niland Company warrants to repair or replace, at our option, any equipment that fails due to defects in material or workmanship within one year from date of shipment. This warranty does not include failures as a result of improper installation, mishandling or misapplication. This guarantee is limited to repair or replacement only and does not include reimbursement for expense of installation, removal of equipment, transportation or any other expenses that may be incurred. Authorization must be obtained from Niland Company in El Paso, Texas before any material is returned.

Catalog Name: N-18-F5-12-DV-2-CP-5015 Date: 02.15.18

Revision History: N/A Revision #: 0

Niland Approval: Luis M. Gomez Customer Approval: \_\_\_\_\_ Page: 3 of 4



# Niland Company

NILAND COMPANY • PH: (915) 779-1405 • FAX: (915) 779-3618 • E-MAIL: INFO@NILANDCO.COM  
 320 N. Clark El Paso, Tx 79905 • PH: 800-848-9013 • FAX: 888-779-3065 • WEB PAGE: HTTP://www.nilandco.com

# CAPITOL SERIES

## CP-5015

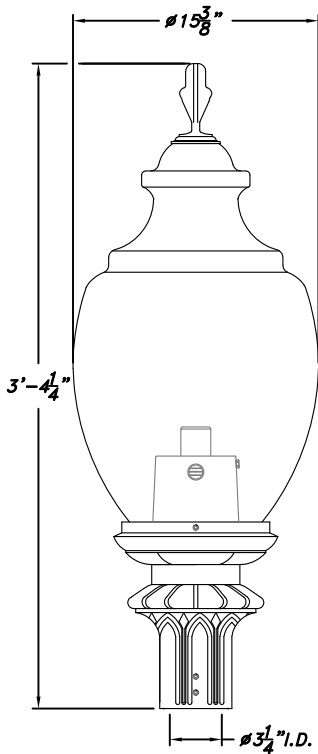

SCALE: 1" = 1'-0"

E.P.A.=2.53 SQ.FT.

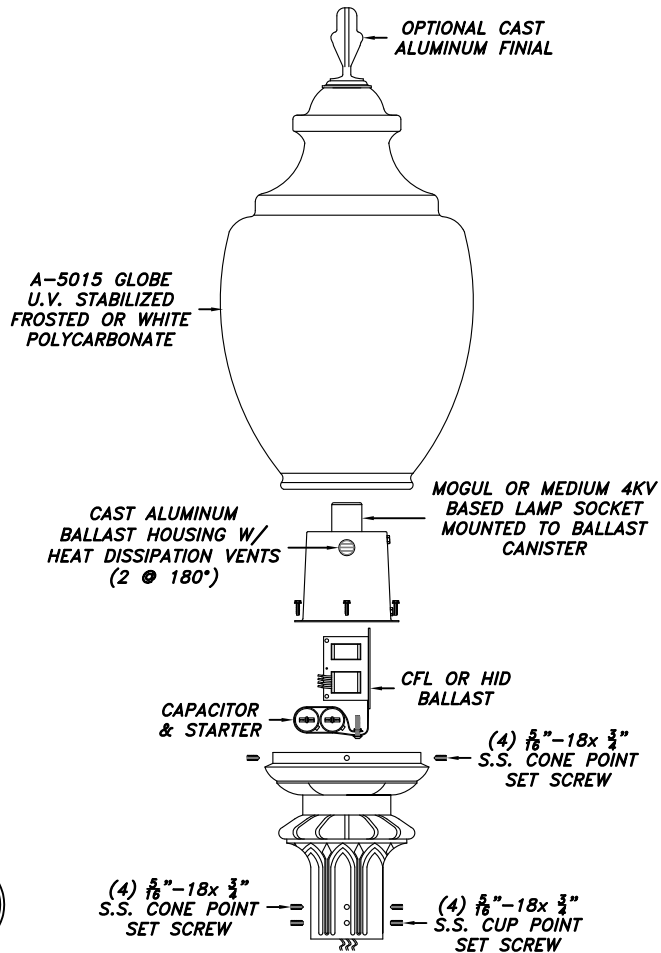

**EXAMPLE**

CP-5015-PSMH-150-208-BLK

CP-5015- \_\_\_\_\_ - \_\_\_\_\_ - \_\_\_\_\_ - \_\_\_\_\_  
 Series Globe Ballast Wattage Voltage Color

GLOBE	LIGHT SOURCE	WATTAGE-SOCKET MEDIUM MOGUL	VOLTAGE	COLOR OF POWDER COAT FINISH
<input type="checkbox"/> FROSTED (CLEAR) <input type="checkbox"/> WHITE (MILKY)	<input type="checkbox"/> INC <input type="checkbox"/> CFL <input type="checkbox"/> HPS <input type="checkbox"/> PSMH <input type="checkbox"/> LED	<input type="checkbox"/> 50w <input type="checkbox"/> 70w <input type="checkbox"/> 100w <input type="checkbox"/> 150w <input type="checkbox"/> 175w <input type="checkbox"/> 250w	<input type="checkbox"/> 120v <input type="checkbox"/> 208v <input type="checkbox"/> 240v <input type="checkbox"/> 277v <input type="checkbox"/> 480v MULTITAP <input type="checkbox"/> 120v 240v <input type="checkbox"/> 208v 277v PLEASE SPECIFY VOLTAGE	<input type="checkbox"/> (BLK) BLACK <input type="checkbox"/> (BRZ) BRONZE <input type="checkbox"/> (GRN) GREEN <input type="checkbox"/> (HG) HAND BRUSHED GREEN <input type="checkbox"/> (HR) HAND BRUSHED GRAY <input type="checkbox"/> CUSTOM _____

### LUMINAIRE SPECIFICATION

**HOUSING**

The post top shall be core cast aluminum. Aluminum shall be certified as pure #356 alloy, free of any porosity, foreign materials or cosmetic fillers. Castings shall be uniform wall thickness with no warping or mold shifting. Minimum wall thickness shall be 3/16". Electrical components are mounted in the ballast canister. The ballast canister shall be mounted in the post top with three stainless steel screws. A optional refractor will be a upgrade refractor globe or borosilicate glass refractor designed for either a type III or type V light distribution pattern.

**ELECTRICAL**

All electrical components and materials shall be UL-recognized and wired by a certified UL technician. All Niland ballasts are high power factor rated for -30°C/-20°F starting. Medium and Mogul base sockets are 4 KV rated. The electrical assembly is prewired with quick disconnects for servicing. Fixture shall be UL certified for wet locations.

**MOUNTING**

Fixture shall be mounted to 3"O.D.x3"H. tenon with stainless steel allen head set screws (8 @ 90°)

**RELAMPING**

The globe is removed by loosening (4) S.S. Allen Head Screws on fitter.

**FINISH**

Fixture finish shall consist of degreasing, phosphate acid etching with 140+ deionized water, rinsed, oven dry off and top coated with a thermoset TGIC super polyester powder coat finish designed not to chalk or fade for many years. All Niland Company powders must pass a minimum 3000-hour salt spray test for corrosion resistance.

**CERTIFICATION**

The Fixture shall be UL-Listed for wet location use, and all HID listings.

**WARRANTY**

Fixture shall be warranted to be free of defects for five years. Ballast components shall carry the ballast manufacturers limited warranty of two years.

**PHOTOMETRICS**

Complete photometric data for all fixtures is available in IES-formatted 3.5 disks. A certified independent laboratory performs all testing. Call the Niland Company directly for more information.

Catalog Name: N-18-F5-10-DV-2-CP-5015 Date: 02.15.18  
 Revision History: N/A Revision #: 0



# Niland Company

Niland Approval: Luis M. Gomez Customer Approval: \_\_\_\_\_ Page: 4 of 4